

GUJARAT INDUSTRIES POWER COMPANY LIMITED

TENDER FOR PROCUREMENT OF NON-METALLIC EXPANSION JOINTS

Bid No.: GIPCL/MATLS/ NMEJ SUPPLY/2024-25



INSTRUCTIONS TO BIDDERS & CONDITIONS OF CONTRACT

INDEX

<u>Sr. No.</u>	<u>PARTICULARS</u>
(1)	<u>NOTICE INVITING TENDER (NIT)</u>
(2)	<u>SECTION – A</u> (Instructions to Bidders)
(3)	<u>SECTION– B</u> (Instructions to Bidders for online tendering and E-Reverse Auction)
(4)	<u>SECTION – C</u> (General Conditions of Contract)
(5)	<u>SECTION – D,</u> (Technical Details) ANNEXURES, Price Bid Format
(6)	<u>SECTION – E</u> (Annexure and Forms) Forms of PBG, EMD, Deviation Sheet, Declaration for Contractual Disputes, Particulars of Bidder
(7)	<u>DRAWINGS</u>

NOTICE INVITING TENDER (NIT)

TENDER NO.: GIPCL/MATLS/ NMEJ SUPPLY/2024-25

Name of work	PROCUREMENT OF NON-METALLIC EXPANSION JOINTS
Place of Supply	GUJARAT INDUSTRIES POWER CO. LTD, Surat Lignite Power Plant (SLPP) At & Post: Nani Naroli Taluka: Mangrol Dist: Surat pin: 394112 (Gujarat)
Quantity	Quantity shall be as per Section-D
Non-Refundable Tender Fee	Rs. 2,950/- by Demand Draft/RTGS in favor of GIPCL and payable at Vadodara as per clause No.06 of Section A.
EMD	Rs. 36,240/- (Rs. Thirty-Six Thousand Two Hundred Forty only) as per clause No.06 of Section A.
Security Deposit	10% of Basic Order Value (excluding Taxes & Duties.) Valid for Guarantee Period in favor of Gujarat Industries Power Company Ltd as per Clause No.01 of Section C, GCC.
Submission of EMD other supporting documents for technical Bid in physical form	On or before due date during office hours at office of GIPCL, P.O. Ranoli – 391350 Dist.: Vadodara, Gujarat – India

NOTES:

1. Amendment / corrigendum of the tender document, forms, schedules, etc... may be done any time by the GIPCL during the period of publication of Tender in the website. The Bidders are required to visit the website regularly till the last date & time of Bid submission.
2. GIPCL reserves the right to reject any or all the tenders without assigning any reason thereof.
3. The Bidders are required to quote the rate strictly as per the terms and conditions mentioned in the tender document, adhering to technical specifications as well.

4. The Bidders are required to submit their Bids online through the website www.nprocure.com.
5. The EMD and other supporting documents are to be submitted in physical form only at the following address:-

**General Manager (Materials & Contracts)
Gujarat Industries Power Company Limited,
P.O. Ranoli – 391350
Dist.: Vadodara.**

SECTION-A

INSTRUCTIONS TO BIDDERS

1. PLANT SYNOPSIS

Gujarat Industries Power Company Limited (GIPCL) (henceforth be named Company/GIPCL), is a Premier Power Utility in the State of Gujarat with an installed capacity of 1184.4 MW comprising of various conventional and renewable projects.

GIPCL commissioned its first power project ; a 145 MW gas based combined cycle power plant in 1992 at Vadodara. It expanded its capacity 165 MW Naptha and gas based Combined Cycle Power Plant at Vadodara in 1997. GIPCL has commissioned 1MWp Distributed Solar Power Projects at two locations in Gujarat viz. at Village: Amrol, Dist.: Anand and at Village: Vastan, Taluka Mangrol, Dist.: Surat.

Surat Lignite Power Plant (SLPP) with four units of 125 MW capacity each is located at Village: Nani Naroli, Taluka: Mangrol, District: Surat in Gujarat. GIPCL has also operating its own captive Lignite and Lime Stone Mines close to the Power Plant. The Power Plant is based on Circulating Fluidized Bed Combustion (CFBC) technology for the Boilers, where Lignite is burnt along with Lime Stone in the Combustor of the Boiler.

It commissioned 5 MW solar power station at SLPP in 2012. Also, GIPCL has commissioned 1MWp Distributed Solar Power Projects at two locations in Gujarat viz. at Village: Amrol, Dist.: Anand and at Village: Vastan, Taluka Mangrol, Dist.: Surat.

GIPCL has successfully commissioned a 2 x 40 MW Solar Project in 2017 as well as a 75 MW Solar Power Project in 2019 at Gujarat Solar Park, Village Charanka, Dist.: Patan. GIPCL has also successfully commissioned 112.4 MW wind farms at different location of Gujarat. The company has successfully commissioned 112.4 MW Wind Generation capacity at various locations in Gujarat in the period 2015-17.

GIPCL has successfully commissioned a 100 MW Solar PV project at the Raghanesda Solar Park, Gujarat.

Surat Lignite Power Plant (SLPP) is accessible by road from Kim and Kosamba, which are on Mumbai-Ahmadabad highway. From Kosamba, SLPP is around 32 KM, out of which 27 KM is part of the National & State Highway and balance 5 KM is District Road. From Kim, SLPP is around 18 KM, out of which 13 KM is the State Highway and balance 5 KM is District Road. The nearest Broad Gauge Railway Line is at Kim, which is around 21 KM from the SLPP. Surat is approximately 50 KM from the SLPP. Location Map for SLPP is as under.

2. SCOPE OF SUPPLY:

Detail Scope of Supply, Technical Specifications for Procurement of NMEJ is mentioned in Section-D.

3. GENERAL INSTRUCTIONS

- 3.1 The Bidders who are interested in participating in the tender must read and comply with the instructions and the Terms & Conditions contained in the tender documents.
- 3.2 The Bids shall be filled in by the Bidders clearly, neatly and accurately. Any alteration, erasures or overwriting shall be liable to make the tender invalid unless the same is neatly carried out and attested over the full signature of Bidder. The decision of the Company to interpret the information and rates filled in by the Bidder shall be final and binding on the Bidder.
- 3.3 The Bidders are requested to make themselves fully conversant with the General Conditions of Contract, Special Conditions of Contract, Technical Specifications, Site conditions, Safety & Health Aspects and Norms to be observed etc. before submitting their bids so that no ambiguity arises in these respects subsequent to submission of the Bids.
- 3.4 Before quoting the rates, the Bidder must visit site and should go through the specifications, scope of work etc. and get himself fully conversant with them. The Bid should include cost of mobilization and cost to adhere to all Safety Norms as described in the tender. No relaxation or request for revision of quoted/accepted rates shall be entertained subsequent to the opening of Bid on account of mobilization or Safety costs.
- 3.5 Bidder has to submit all the information as per required Bid document. Failure to furnish all the information as per required Bid documents or submission of a Bid containing deviations from the contractual terms and conditions, specifications and requirements, shall be rejected.
- 3.6 The Bids shall be submitted within the time frames set out in the Notice Inviting Tender ('NIT') and Bids submitted thereafter shall not be accepted and considered.
- 3.7 The tender documents shall not be transferable.
- 3.8 The Bidders are expected to examine all instructions, forms, terms & specifications in the Bid documents and to get fully acquainted themselves with all the conditions and matters which may affect the subject matter of the work/tender or the cost thereof. If any Bidder finds any discrepancies or omissions in the specifications and documents or any doubt in true meaning or interpretation of any part, he shall seek necessary clarifications in writing if required.
- 3.9 Conditional offers shall not be considered and liable to be rejected.
- 3.10 The Company reserves the right to extend the deadlines for submission of the Bids by giving amendments.
- 3.11 During evaluation of Bids the Company may, at its discretion ask the Bidder (s) for clarification of their Bid. The request for clarification and the response shall be in writing and no change in prices or substance of the Bid shall be sought, offered or permitted.
- 3.12 The Company reserves the right to amend/ modify the Bidding documents at any time prior to the deadline for submission of Bids, either at its own discretion or in response to the clarification requested by a prospective Bidder. In such case, the Company may in its discretion extend the deadline for submission of Bids in order to facilitate the prospective Bidders for incorporating the effect of the amendment in their Bids.
- 3.13 The Bidders shall bear all costs and expenses associated with the preparation and submission of their respective Bids, to attend meetings or conferences, if any, including any pre-award discussion with the successful Bidder, technical and other presentations etc. and the Company shall not be liable for any expense thereof.
- 3.14 If the successful Bidder is consortium/joint deed of undertaking of company, the Consortium leader/Bidder shall accept joint and several responsibilities and liabilities for all obligations under the Contract.
- 3.15 Timely and satisfactory completion of the work and strict adherence to the allotted time frames for jobs shall be the essence of the contract.

3.16 The Company reserves the right to qualify/disqualify any applicant without assigning any reason.

3.17 The Bidder shall be disqualified if any untrue statement or misrepresentation is made in the Bid forms, attachments and other supporting documents submitted by the Bidder.

4. ELIGIBILITY CRITERIA

The following criteria shall be adopted for qualifying the Bidders for further proceeding.

4.1 Bidder should be Manufacturer or an authorized dealer of tendered items. Bidder shall submit authorized dealership certificate from their manufacturer.

4.2 Bidder should have supplied the similar tendered items to 125 MW or above capacity Boilers. Bidder shall submit Purchase Order Copies of similar tendered items in their name supplied to any Govt/PSU/IPP/Pvt Company within last five years. The experience should be either of the following:

A. One Executed PO Copy of Supply of above-mentioned items costing not less than the amount equal to 29 Lacs.

OR

B. Two Executed PO Copies of Supply of above-mentioned items each costing not less than the amount equal to 18.12 Lacs.

OR

C. Three Executed PO Copies of Supply of above-mentioned items each costing not less than the amount equal to 14.50 Lacs.

Bidder should specifically mention fulfilling of above criteria in his offer along with details of Purchase orders & Supply completion certificates issued by clients for each submitted PO.

4.3 The Bidder should have minimum average turnover of **Rs. 75 Lacs** per annum during last three financial years. Balance Sheet of the company along with profit and loss account to be submitted duly audited by chartered accountant. The Balance sheet must be in the name of the Company who is purchasing the tender document any type of MOU for this purpose shall not be entertained.

Note: In case, the annual turnover is less than the statutory guideline which does not require audit, the bidder shall submit the turnover certificate from Chartered Accountant

4.4 The net worth of the bidder should be positive as evidenced from audited accounts of last financial year.

4.5 EMD & Tender Fee: **The EMD and tender Fee** shall be accompanied in the form of DD /Bank Guarantee/RTGS given by Bank as described in subsequent clause.

4.6 The Bidder has to submit INCOME TAX Permanent Account Number (PAN), GST Registration No. of the firm. Copies of the same shall be submitted.

4.7 In case Bidder is a Consortium/Joint deed of undertaking of company, the above requirements/credential of consortium leader/bidder shall be considered unless otherwise specifically mentioned in the tender.

- 4.8 If Bidder or its Partner(s) or Director(s) is /are/was Black Listed / Deregistered / Stopped or banned from dealing in the past by any Govt, of Gujarat Undertakings / Depts. / Authorities and Govt. of Gujarat supported companies / undertakings / organizations, Bid of that party may be liable to be rejected. Bidder agrees and undertakes to accept decision of GIPCL in this regards as final and binding on the Bidder without any demur and that no further correspondence shall be done in this regard at any stage. Bidder shall have to submit "Declaration for Contractual Litigations" as amended in Annexure / Form attached
- 4.9 All the tender documents shall be submitted with sign and stamp on each & every page. Attested copies of relevant documents duly signed & seal on each & every page shall be submitted. GIPCL may verify the documents, experience certificates issued by concern authority. After opening of technical Bid, if any required attested documents found missing in the Technical Bid submitted by the Bidder, the tender inviting authority may inform to that Bidder by E-mail to submit the missing required documents within stipulated time limit. If Bidder/Bidders fail to submit within stipulated time, their Bid will be declared technically disqualified and no further correspondence will be entertained.
- The Bidder shall submit all the evidences, documents, attested copies of purchase orders etc as a proof with EMD, Tender Fee and also provide the requisite details for meeting the prequalification requirements. GIPCL will verify the experience, performance, capability & strength of Bidders, independently for executing the job. GIPCL may visit the site & consult the owner of the industry/property where similar job is executed by the Bidder. GIPCL reserves the right to accept/cancel/reject any/all Bids without assigning any reason thereof. The tenders of qualified Bidder/Bidders shall only be considered for further evaluation.
- 4.10 GIPCL reserves the right not to consider bid of vendor who has track record of Non-Compliance/ Non-Performance/Non-Supply/ Cancellation of Work Order/Purchase Order in past with GIPCL.

5. LANGUAGE OF BID

The Bid prepared by the Bidder, and all correspondence and documents relating to the Bid exchanged by the Bidder and the Company, shall be written in the English language. Any printed literature furnished by the Bidder, written in another language shall be accompanied by an English translation for the purpose of interpretation of the Bid.

6. EARNEST MONEY DEPOSIT (EMD) AND TENDER FEE

- 6.1 An EMD of **Rs. 36,240/-** and Nonrefundable Tender fee **Rs. 2,950/-** shall accompany with Bid. Tender fee & EMD shall be submitted in the form of a crossed bank Demand Draft in favor of Gujarat Industries Power Co. Ltd. **and payable at Vadodara.**
- 6.2 The EMD, in alternative, may be submitted in the form of irrevocable Bank Guarantee in favor of Gujarat Industries Power Company Limited from any Schedule Public Sector Bank or Schedule Private Sector as per Performa of BG enclosed under Section-E.
- 6.3 EMD & Tender fee may also be submitted through online payment gateway of company's website: www.gipcl.com (online Payment Form) as per detail provided in Section-E. Generated receipt must be submitted with technical bid.
- 6.4 In case EMD is paid in the form of BG, the same shall be valid for a period of 180 days after the due date for submission of the bid.

- 6.5 The EMD of the Successful bidder will be returned after payment of Security Deposit by successful bidder.
- 6.6 The earnest money deposit paid in the form of Demand draft/BG/Online will be refunded to the Unsuccessful BIDDER as soon as the tender is finalized and after award of LOI/Work Order.
- 6.7 GIPCL reserves the right to accept/reject/refloat the tender, In no case tender fee shall be refunded.
- 6.8 Any bid not accompanied with EMD & Tender Fee will be rejected.
- 6.9 No interest shall be payable on EMD.
- 6.10 The EMD will be forfeited if the BIDDER (i) withdraws his tender after acceptance or (ii) withdraws his tender before the validity date of the tender.

6.11 SCHEDULE OF EMD

EMD, Tender Fee and all the documents asked in the tender (except price bid) shall be submitted with dully signed and stamp in physical on or before due date.	Address for Submission: General Manager (Materials & Contracts) Gujarat Industries Power Company Limited, P.O. Ranoli – 391350 Dist.: Vadodara, Gujarat - India
--	--

7. SUBMISSION OF BIDS

A: MODE OF SUBMISSION

The Bids shall be submitted in two parts along with EMD within dates specified in NIT as under:-

- (a) Pre-qualification and Techno-commercial Bid without price.
- (b) Price Bid.

a) Pre-Qualification and Techno-commercial Bid without price:

The following Documents shall also be submitted along with EMD in Physical Form to GIPCL-Vadodara.

The following supporting documents shall also be submitted along with EMD in physical form:

1. The Tender Documents of (Section-A to Section-E) duly signed in all pages without price bid along with techno-commercial deviations, if any shall accompany the bid. If you don't have deviations then write "NIL" in the deviation sheet and then submit with sign & stamp.
2. EMD, Tender FEE in the form of DD/BG/Online with receipt.
3. Proof of minimum eligibility criteria as per clause no.04 of Section A.

b) Price Bid:

- 1) Price Bid shall be submitted only in soft form through **(n) Procure Only**.

8. EVALUATION & COMPARISON OF BIDS

- 8.1** GIPCL shall evaluate the Bids received and accepted by it to ascertain the overall lowest/item wise lowest evaluated Bid in conformity with the specifications of the tender documents at his sole discretion.
- 8.2** The Technical Bids will be examined for minor matters regarding qualification of bids. Subsequent to correspondence with the respective bidders, the decision of GIPCL will be final.
- 8.3** All responses to requests for clarifications shall be in writing and shall be presented to the Company through e-mail or in a sealed envelope on or before the given date requested by the Company. If the Technical clarifications sought by the Company do not reach the Company on or before due date, the Bid will be rejected.
- 8.4** The comparison of all the Bids shall be carried out with reference to the scope of work as per the technical specification. Any deviation/omission shall be evaluated at highest quoted price of the deviation/omission quoted by any of the Bidder. In case a separate price (for omission) is not given by any other Bidder, a reasonable price of the same shall be taken & the same shall be binding to the Bidders.
- 8.5** The commercial deviation, if any, shall be loaded to bring all the Bids at par. The loading shall be carried out at an interest rate of 2% above PLR of SBI.
- 8.6** A Bid to be substantially responsive shall be one which on evaluation confirms to all the terms, conditions and specifications of the Bid documents without any material deviation or reservation.
- 8.7** For the above referred purpose, a 'material deviation' shall be one which:
 - (a) Which affects in any substantial way the scope, quality or performance of the contract, or
 - (b) Which limits in any substantial way and in a manner inconsistent with the Bid documents, GIPCL's right or the Bidder's obligations, under the contract, or
 - (c) Whose rectification would affect unfairly the competitive position of other Bidders presenting substantially responsive Bids.

9. METHOD OF TENDERING/SIGNATURE ON BIDS

- (i) The Bid must contain the postal address like name, residence and place of business of the person or persons submitting the Bid and must be signed and sealed by the Bidder with his usual signature. The name of all persons signing the documents shall also be typed or printed below the signature on each page.
- (ii) Bid by a consortium/joint deed of undertaking of company/partnership firm must be furnished with full names of all partners and be signed with the partnership name, followed by the signature and designation of one of the authorised partners or other authorised representative(s). A certified copy of the power of attorney authorizing such partner or representative shall also be submitted.
- (iii) Bids by a Corporation/Company must be signed with the legal name of the Corporation/Company i.e. by the President/Managing Director/Secretary or other person or persons authorised to Bid on behalf of such Corporation/Company. A certified copy of the board resolution/power of attorney authorizing such partner or representative shall also be submitted.
- (iv) The Bidder's name stated on the proposal shall be the exact legal name of the firm.
- (v) Erasures or other changes in the Bid Documents shall be initialed by the person signing the Bid.
- (vi) Bids not conforming to the above requirements of signing shall be disqualified.

10. MODIFICATION AND WITHDRAWAL OF BIDS

- a. The Bidder may modify or withdraw the bid prior to the deadline prescribed for submission of bids.
- b. No Bid shall be modified subsequent to the deadline for submission of Bids.
- c. No Bid shall be withdrawn in the interval between the deadline for submission of Bids and the expiration of the period of bid validity.

11. POLICY FOR BIDS UNDER CONSIDERATION

- a. Bid shall be deemed to be under consideration immediately after opening of the bid and till official intimation of award/rejection made by the Company to the Bidders.
- b. While the Bids are under consideration, Bidders and / or their representative or other interested parties are advised to refrain from contacting by any means, the Company. The Engineer, if necessary, will obtain clarifications on the Bids by requesting for such information from any or all the Bidders, in writing as may be necessary. The Bidder will not be permitted to change the price or substance of the Bid after the Bid has been opened.

12. EFFECT AND VALIDITY OF THE BID

- a. The Bid should be kept valid for acceptance for a period of one hundred and eighty (180) calendar days from the last date of submission of Bids.
- b. The submission of any Bid along with the required documents and specifications shall constitute an agreement that the Bidder shall have no cause of action or claim, against the Company for rejection of his Bid. The Company shall always be at liberty to reject or accept any Bid or Bids at his sole discretion and any action will not be called into question and the Bidder shall have no claim in that regard against the GIPCL.

13. PRELIMINARY EXAMINATION OF BIDS

- 13.1 The Company will examine the Bids for any computational errors, for sureties furnished by bidder, for authentication of documents submitted and completeness of the Bids.
- 13.2 Arithmetical errors will be rectified on the following basis:
 - (a) If there is a discrepancy between the unit price and the total price that is obtained by multiplying the unit price and quantity, the unit price shall prevail and the total price will be corrected & will be binding to the bidders
 - (b) If there is a discrepancy between the Total Bid Amount and the sum of total prices, the sum of total prices shall prevail and the Total Bid Amount will be corrected & will be binding to the bidders.

14. RIGHT OF REJECTION OF TENDERS

14.1 GIPCL reserves the right to accept or reject any Bid or to cancel the Bidding process and reject all Bids at any time prior to award of contract, without thereby incurring any liability to the affected Bidder or Bidders or any obligation to inform the affected Bidder or Bidders regarding the same. GIPCL reserves the right to disqualify any bidder who does not accept GIPCL terms & Conditions.

14.2 Any Tender without EMD will be treated as non-responsive and shall be rejected at the outset & no further correspondence shall be entertained regarding this.

14.3 GIPCL reserves the right to debar any Bidder from participation in future Bids if such Bidder has quoted an abnormally low rate in the Bid document/price Bid.

15. AWARD OF CONTRACT

15.1 GIPCL will award the contract to that bidder whose quotation has been determined to be substantially responsive and evaluated as the overall lowest quotation/item wise lowest quotation in conformity with the requirements of the specifications and documents contained herein, provided further that the bidder is determined and evaluated to be qualified to perform the contract satisfactorily at sole discretion of GIPCL.

15.2 The successful bidder shall be intimated of his selection through the Letter of Intent or Letter of Award/ Purchase Order which shall be sent to him through e-mail, courier.

15.3 GIPCL reserves the right to cancel/short close the contract during the contract period without assigning any reason.

15.4 GIPCL reserves the right to increase or decrease the qty. mentioned in tender inquiry before finalization of order.

15.5 GIPCL reserves the right to split the contract quantity between vendors.

16. ASSIGNMENT AND SUB-LETTING

The Supplier shall not directly or indirectly assign or sub-let total/any part of the contract to any other party or agency.

17. CLARIFICATION OF BIDDING DOCUMENTS

If any Bidder requires any further information or clarification in the Bidding Documents, may notify the Company before one week of last date of submission of online Bid, in writing or by E-mail at the GIPCL's mailing address bcshah@gipcl.com as indicated in the 'Invitation to Bids'. The GIPCL's response (including an explanation of the query) will be sent in writing or by E-mail to all prospective Bidders who have received the Bidding Documents.

18. TIME SCHEDULE

The basic considerations and the essence of the 'Contract' shall be the strict adherence to the time schedule for performing the specified 'Works'.

19. UNDERSTANDING AND CLARIFICATION ON DOCUMENTS AND SPECIFICATION

The Bidder is required to carefully examine the specifications and documents, all the conditions and matters work wise & cost wise. If any Bidder finds any discrepancies or omissions in the specifications and documents or is in doubt for any meaning of any part, he shall request in writing for an interpretation/ clarification to the GIPCL.

All such interpretations and clarifications shall form a part of the Bid documents.

20. PAYMENTS

All the payments against the work order shall be in Indian currency and payable through cheque/RTGS only.

SECTION-B

INSTRUCTIONS TO BIDDERS FOR ONLINE TENDERING

Sr. No	Description
01.	Tender documents are available only in electronic format which Bidders can download from the website https://tender.nprocure.com and It can also be viewed from Company's website www.gipcl.com .
02.	Price bid should be submitted online through the website https://tender.nprocure.com only. No physical submission of price bid will be entertained as it should be furnished on-line only.
03.	Bidders who wish to participate in online tenders will have to procure / should have legally valid Digital Certificate (Class III) as per Information Technology Act-2000, using which they can sign their electronic bids. Bidders can procure the same from any of the license certifying Authority of India or can contact (n)code solutions- a division of GNFC Limited, who are licensed Certifying Authority by Government of India
04.	<p>All bids should be digitally signed. The bidders are required to contact at the below mentioned address for detailed training on on-line tendering and also for requirement.</p> <p>(n)Code Solutions - Division of GNFC Ltd., (n)Procure Cell 501, GNFC Infotower, S.G. Road Bodakdev, Ahmedabad - 380054 (Gujarat)</p> <p>Toll Free : 7359021663 (9:30 AM to 8:00 PM) Email : nprocure@ncode.in</p>

Interested bidders are requested to submit the online tender at least two days in advance from the due date set for on line submission of bid in order to avoid non participation.

E-REVERSE AUCTION:

- 1) GIPCL reserves the right to conduct E-Reverse auction through (n) Procure platform.
- 2) E-Reverse auction shall be conducted amongst (a) the lowest 50% eligible bidders (rounded to the next higher whole number) from the total bids received OR (b) Minimum three (03) lowest bidders, whichever is higher, shall be invited for participation in e-Reverse Auction through n-procure platform.
- 3) Opening Price, Detrimental value and duration for the e-Reverse Auction shall be informed to the qualified bidders before start of e-Reverse Auction.
- 4) After e-Reverse Auction process, L1 bidder shall be decided on Lowest Total Contract Price.
- 5) To participate in e-Reverse Auction, Bidders have to create e-Auction USER ID on <https://e-auction.nprocure.com> that the bidder shall be allowed to participate the e-Reverse Auction.
- 6) In case of any further information regarding online bidding or if a Bidder needs any assistance in accessing/ submission of online bid/ clarification or if training is required for participating in online e-reverse bidding, then the Bidder can contact the following office for assistance or training:

(n) Procure Cell, (n) code solutions-A division of GNFC Ltd.,

Head Office

- **(n)Code Solutions (A Division of GNFC Ltd.)**

14th Floor, Tower One, Road 5C, Zone 5,
Gujarat Information Finance Tech City (GIFT City),
Gandhinagar - 382355. India.
Toll Free Number : 7359-021-663
Support: 079- 4000 7517/515/514
Email : nprocure@ncode.in

For further assistance visit website <https://e-auction.nprocure.com/Home/Contact>

SECTION-C GENERAL CONDITIONS OF CONTRACT

1) CONTRACT SECURITY DEPOSIT/ PERFORMANCE BANK GUARANTEE

As a Contract Security, the successful Bidder, to whom the work is awarded, shall be required to furnish a Performance Bank Guarantee (PBG)/Contract security deposit in favor of Gujarat Industries Power Company Limited for guarantee amount at 10% of the Purchase Order Value (excluding Taxes & Duties) valid for 24 months from the date of receipt of materials from list of banks mentioned in the BG format attached in SECTION-E and it shall guarantee the faithful performance of the 'Contract' in accordance with the terms and conditions specified in these documents and specifications. Any defect or poor workmanship found during guarantee period, vendor shall replace the Material at free of cost. GIPCL reserves the right to forfeit Performance Bank Guarantee (PBG)/Contract security deposit.

Contract Security deposit shall be submitted within Twenty One (21) days from date of receipt of materials at site.

The (PBG)/Contract security will be returned to the Supplier without any interest after successful completion of guarantee period and on fulfilling contractual obligations throughout the period. However, any delay in submission of initial SD will result in equivalent late release of entire SD after guarantee period.

2) PRICE

Price quoted by the bidder should be firm and no price increase will be allowed to the supplier during the contract period. The Bidder shall deliver materials from their works to GIPCL-SLPP on door delivery basis. Prices shall be inclusive of transportation, inspection, packing and forwarding, transit Insurance, Octroi, Stacking, Loading/unloading and any other charges etc. However applicable GST shall be paid extra at actual.

3) PRE- DISPATCH INSPECTION

GIPCL will carry out Pre-dispatch inspection. Bidder shall inform 15 days in advance for pre-dispatch inspection.

4) DELIVERY AND PENALTY

Bidder shall deliver the materials within **Ten (10) weeks** from date of written intimation/after issue of PO to GIPCL-SLPP failing to which (if delay more than one week after mentioned delivery period) penalty of 0.5% per week (07 days) per order value/item value (excluding T&D) shall be levied by GIPCL for late supply / undelivered items maximum up to 10% of items value under order. Material should be directly delivered to GIPCL-SLPP from your works.

Delivery is the essence of the contract and if the delivery is not made as stipulated, GIPCL shall be at liberty to procure the material at Bidder's risk and cost and if hereby any extra expenditure is involved, the same will be debited to Bidder's account. If GIPCL is unable to procure the material from other source in time and if GIPCL suffers any consequential loss, Bidder will have to bear the same. GIPCL in that case (if the delivery is not made as stipulated) will forfeit Security Deposit / Performance Bank Guarantee or EMD and can also lodge claim against party for damage incurred.

5) PAYMENT TERM

100% of the order value of the supplied lot of materials will be released within 30 days from receipt of materials at site, after submission of PBG and acceptance by user department after verification of technical documents (mentioned in Section-D) like Material Test Certificates, original invoices etc, if any as per the PO terms.

6) GUARANTEE

Guarantee period shall be 18 months from the date of installation/commissioning of materials or 24 months from the date of receipt of material at GIPCL-SLPP, whichever is earlier.

7) LOSS AND DAMAGES

Any loss or damages and deterioration to the material in transit shall be at the cost of the suppliers. It shall be at the discretion of the GIPCL to reject the damaged or spoilt material, if so noticed.

8) INVOICE

Original invoice should be sent at GIPCL- Baroda and duplicate invoice along with challan should be sent at GIPCL-SLPP Store. (Mention the Purchase Order No. in Invoice and challan)

9) APPROVAL

The Material supplied will be subject to GIPCL approval and inspection at GIPCL-SLPP premises. Our decision for acceptance or rejection of the goods will be final and binding on you.

10) TRANSIT INSURANCE

The goods supplied under the contract shall be fully insured against loss or damage incidental to manufacture or acquisition, transportation, storage and delivery to destination. Insurance is to be provided by the supplier at his cost.

11) QUANTITY OF SUPPLIED MATERIAL:

Quantity recorded at our GIPCL-SLPP Store will be taken as the basis of payment.

12) TERMINATION OF CONTRACT BY GIPCL

Supplier shall be responsible to complete the jobs within agreed time schedule and in case Supplier fails to complete the job, GIPCL shall recover from his bill, Security Deposit and / or whatsoever for expenses incurred to complete the job with additional 10% overhead charges.

In case if Supplier's services are not found satisfactory with respect to time bound completion of work, workmanship then GIPCL has right to terminate the contract at any time without assigning any reason and will make the alternate arrangement at the risk & cost of Supplier.

GIPCL may terminate the contract after due recoveries of pending jobs/damages if any of the following events occur –

- i. Supplier is adjudged as insolvent.

- ii. Supplier has abandoned the contract.
- iii. Supplier fails to proceed with the work with due diligence as per requirements of the contract.
- iv. Supplier has neglected or failed persistently to observe or perform any of the acts, matters or things, which as per the contract are to be observed and performed by the Supplier.
- v. Supplier repetitively violating the safety norms for more than three incidents.
- vi. Any major contradiction of applicable labour laws.
- vii. Any major deviations from contractual terms and conditions including quality of job.
- viii. GIPCL reserves the right to terminate the contract without giving any reason whatsoever.
- ix. GIPCL reserves the right to terminate the contract without giving any reason whatsoever and forfeit the PBG.

13) FAILURE & TERMINATION

If the SUPPLIER after receipt of written notice from the GIPCL/ ENGINEER requiring compliance, with such further drawings and / or the GIPCL /ENGINEER instructions fails within seven days to comply with the same, the GIPCL /ENGINEER may employ and pay other agencies to execute any such work whatsoever as may be necessary to give effect thereto and all costs incurred in connection therewith shall be recoverable from the SUPPLIER by the GIPCL on a certificate by the GIPCL/ENGINEER as a debt or may be deducted by him from any money due or to become due to the SUPPLIER.

If the supplier fails to execute the work or fails to mobilize the resources and equipment as per directions of GIPCL / ENGINEER within the time frame given and/or violating the GIPCL's safety rules & regulations, ENGINEER/ GIPCL shall get the work done by third party at the risk & cost of the CONTRACTOR with additional 10% overhead charges of GIPCL and all costs incurred in connection therewith shall be recoverable from the CONTRACTOR by the GIPCL /ENGINEER as a debt or may be deducted by him from any money due or to become due to the supplier.

14) SETTLEMENT OF DISPUTES

- a. Any disputes or difference of opinion between parties arising out of the contract to the extent possible shall be settled amicably between the parties. If amicable settlement cannot be reached all the disputed issues shall be resolved through arbitration before a Sole Arbitrator appointed by Managing Director, GIPCL according to the provisions of The Arbitration & Conciliation Act-1996, as amended from time to time. The place of arbitration shall be at Vadodara/ Surat or any other place within state of Gujarat.
- b. Work under the contract shall be continued by the contractor during arbitration proceedings unless GIPCL shall order suspension thereof or any part thereof in writing or unless the matter in such work cannot possibly be continued unless the decision of the Arbitration proceedings is obtained.

15) INTERPRETATION OF CLAUSE

In case of disputes as regards interpretation of any of the clauses or specification, the decision of Head of Management (HOM)-GIPCL will be final and binding on the supplier.

16) FORCE MAJEURE

The performance of the obligations herein contemplated may be suspended without incurring the penalty in the event of the subsistence of Force Majeure conditions.

If a Force Majeure situation arises, the affected Party shall promptly notify the other Party in writing of such conditions and the performance shall be suspended as per mutual agreement.

For the purposes of this clause, 'Force Majeure' means an event beyond the control of the Party and not foreseeable by the Party and shall include events of floods, explosions, riots, wars, hurricane, epidemics, any other Act of God, quarantine restrictions, terrorism, government actions and provided always that such acts result in the impossibility of the further performance of the contract.

17) INDEMNITY

The Supplier shall indemnify and keep harmless GIPCL from and against all actions, proceedings, claims, demands, losses, costs, damages and expenses whatsoever which may be brought against or suffered by GIPCL which it may sustain, pay or incur as a result of or in connection with the performance/ purported performance/ non-performance of the contract by the Supplier.

In case, in any litigation pertaining to labour employed through Supplier if any direction or order is issued by court at any point of time the Supplier shall comply with and implement such direction or order whether passed at the time of award of contract or during the pendency of contract. Further, the Supplier shall indemnify the GIPCL against all consequences arising and affecting GIPCL owing to the compliance of the orders by the Supplier.

18) GOVERNING LAW AND JURISDICTION

This tender document and contract shall be governed by the laws of India and the Courts at Vadodara shall have jurisdiction regarding the same.

SECTION-D, TECHNICAL SPECIFICATIONS, DRAWINGS AND PRICE BID FORMAT

1) TECHNICAL SPECIFICATIONS

ANNEXURE- I

Technical specifications for Insulation bolster at C to C

Item code no – 710106107

1. MOC of bolster will super wool encased with Special high temperature resistance glass fabric. The Bolster shall be covered with SS wire mesh and High temperature resistance fabric (glass fabric cloth).
2. The bolster selected for the expansion joint must withstand high temperature and pressure. It should withstand temperature up to 1100 ° c and pressure +/- 300 mbar.
3. An insulator bolster will have flange on both sides, of which the flanges will be bolted on the fabric fixing flange, below the main fabric.
4. The bolster selected shall match the fabric specifications as per drawing.
5. Bolster shall be supplied in two equal parts.

NOTE:

- 1) Bolster joining kit: Approx Qty: Needle: 01No, High Temp. Thread: 50 mtr, PTFE coil: 5 mtr, SS Wire: 15 mtr for each Bolster etc. shall be supplied with NMEJ.
- 2) Locking arrangement (Anchor) for bolsters & flange reinforcement of quantity: 450Nos per bolster (L type anchor with locking washer) shall be provided by party in separate box.
- 3) For Each quantity of C to C NMEJ consider 04 Joints for one Bolster for supply of above joining kit.
- 4) **Packing Slip shall be submitted with Supply of Material mentioning the quantity of material inside the BOX.**

Supervisory Service:

- 5) Supervisory services during installation and jointing of fabric and bolster shall be provided by **supplier at free of cost** for each quantity of C to C NMEJ. GIPCL will intimate for the same in 7 days in advance.

Guarantee term:

Guarantee period shall be 18 Months from the date of installation/commissioning of NMEJ at site or 24 months from the date of receipt of material at SLPP, GIPCL whichever is earlier.

ANNEXURE- II

Technical specifications for NMEJ fabric at cross over duct (COD) to Backpass inlet Item code no – 710902100

1. The fabric selected for the expansion joint must withstand high temperature and pressure. It should withstand temperature up to 1100 °C and pressure +/- 300 mbar.
2. The fabric will consist of following layers or equivalent from outer to inner side.
One layer of PTFE coated & both side laminated Glass fabric – 0.95 mm thick
One layer of Skived Virgin PTFE -0.2 mm thick
One layer of Needled Glass Felt – 9mm Thick
One layer of Super Wool 128 kg/m³ – 12 mm thick
One layer of High Silica 1250 Fabric -1.1 mm thick
FR: The flange reinforcement shall be done with Elastomer coated glass fabric on either side.
3. Fabric must have proper gas sealing, strong end joints, better acid & weather resistance, higher strength & flexibility etc. (End points must have properties that they are to be joined by welding joint/heated joint & not by paste joint.)
4. Flange enforcement is to be provided on either side without hole punch.
5. The width of fabric is **500 mm** and length is **26500 mm**, (Please Refer attached drawing)
6. The outer & inner side of fabric must be clearly indicated on fabric at every 2 meter length.
7. The fabric selected must have sulphur & chlorine corrosion resistance.
8. Supervisory services during installation and jointing of fabric and bolster shall be provided by supplier at free of cost.

Technical specifications for Insulation bolster at cross over duct (COD) to Backpass inlet Item code no – 710902042

6. MOC of bolster will super wool of 128 Kg/m³ density encased with Special high temperature resistance glass fabric. The Bolster shall be covered with SS wire mesh 16x16, 0.44 mm thick and high silica 600 of 0.5 mm thick.
7. The bolster selected for the expansion joint must withstand high temperature and pressure. It should withstand temperature up to 1100 °C and pressure +/- 300 mbar.
8. An insulator bolster will have flange on both sides, of which the flanges will be bolted on the fabric fixing flange, below the main fabric.
9. The bolster selected shall match the fabric specifications as mentioned above.
10. **Length of the Bolster according to the Fabric length.**
11. Bolster shall be supplied in one piece without flange.

NOTE:

- 1) Fabric and bolster joining kit: Approx Qty: Needle: 01No, High Temp. Thread: 100 mtr, PTFE coil: 10 mtr, SS Wire: 30 mtr for each fabric etc. shall be supplied with NMEJ.
- 2) Locking arrangement (Anchor) for bolsters & flange reinforcement of quantity: 300Nos per bolster (L type anchor with locking washer) shall be provided by party in separate box.
- 3) Fabric shall have corner bends & match with our existing arrangement.
- 4) Packing Slip shall be submitted with Supply of Material mentioning the quantity of material inside the BOX.

Supervisory Service:

- 5) Supervisory services during installation and jointing of fabric and bolster shall be provided by **supplier at free of cost** for each quantity of NMEJ. GIPCL will intimate for the same in 7 days advance.

Guarantee term:-

Guarantee period shall be 18 Months from the date of installation/commissioning of fabric at site or 24 Months from the date of receipt of material at SLPP, GIPCL whichever is earlier.

ANNEXURE- III

Technical specifications for NMEJ fabric at Cyclone to Seal pot inlet Item code no – 710902060

9. The fabric selected for the expansion joint must withstand high temperature and pressure. It should withstand temperature up to 1100 °C and pressure +/- 300 mbar.
10. The fabric will consist of following layers or equivalent from outer to inner side.
One layer of PTFE coated & both side laminated Glass fabric – 0.95 mm thick
One layer of Skived Virgin PTFE -0.2 mm thick
One layer of Needled Glass Felt – 9mm Thick
One layer of Super Wool 128 kg/m³ – 12 mm thick
One layer of High Silica 1250 Fabric -1.1 mm thick
FR: The flange reinforcement shall be done with Elastomer coated glass fabric on either side.
11. Fabric must have proper gas sealing, strong end joints, better acid & weather resistance, higher strength & flexibility etc. (End points must have properties that they are to be joined by welding joint/heated joint & not by paste joint.)
12. Flange enforcement is to be provided on either side without hole punch.
13. The width of fabric is **530** mm and length is **10000** mm.(Please Refer attached drawing)
14. The outer & inner side of fabric must be clearly indicated on fabric at every 2 meter length.
15. The fabric selected must have sulphur & chlorine corrosion resistance.

Technical specifications for Insulation bolster at Cyclone to Seal pot inlet Item code no – 710902061

12. MOC of bolster will super wool of 128 Kg/m³ density encased with Special high temperature resistance glass fabric. The Bolster shall be covered with SS wire mesh 16x16, 0.44 mm thick and high silica 600 of 0.5 mm thick.
13. The bolster selected for the expansion joint must withstand high temperature and pressure. It should withstand temperature up to 1100 °C and pressure +/- 300 mbar.
14. An insulator bolster will have flange on both sides, of which the flanges will be bolted on the fabric fixing flange, below the main fabric.
15. The bolster selected shall match the fabric specifications as mentioned above.
16. **Length of the Bolster according to the Fabric length.**
17. Bolster shall be supplied in one piece without flange.

NOTE:

- 5) Fabric and bolster joining kit: Approx Qty: Needle: 01No, High Temp. Thread: 50 mtr, PTFE coil: 5 mtr, SS Wire: 15 mtr for eah fabric and bolster etc. shall be supplied with NMEJ.
- 6) Locking arrangement (Anchor) for bolsters & flange reinforcement of quantity: 300Nos per bolster (L type anchor with locking washer) shall be provided by party in separate box.
- 7) Fabric shall have corner bends & match with our existing arrangement.
- 8) Packing Slip shall be submitted with Supply of Material mentioning the quantity of material inside the BOX.

Supervisory Service:

- 5) Supervisory services during installation and jointing of fabric and bolster shall be provided by **supplier at free of cost** for each quantity of NMEJ. GIPCL will intimate for the same in 7 days in advance.

Guarantee term:-

Guarantee period shall be 18 months from the date of installation/commissioning of fabric at site or 24 months from the date of receipt of material at SLPP, GIPCL whichever is earlier.

ANNEXURE- IV

Technical specifications for NMEJ Dust trap at C to C

Item code no – 710106124

16. The Dust trap selected for the expansion joint must withstand high temperature and pressure. It should withstand temperature up to 1100 °C and pressure +/- 300 mbar.
17. The Dust trap will consist of following layers or equivalent from outer to inner side.
The Dust trap has two parts:

1st Part Consist of following layer:

- a. One layer of SS310 HD WM (Thickness: 0.6 mm)
- b. One layer of HS 1250 (Woven High Silica Fabric)
Thickness: 1.1 mm
- c. Insulation Of super Wool (128 Kg/Cm2)

2nd Part Consist of following layer:

- d. One layer of HS 1250 (Woven High Silica Fabric)
Thickness: 1.1 mm
 - e. One layer of Incoloy WB
- ❖ Pillow of Super wool of density **128 kg/m³** and thickness 50 mm QTY: 5Nos Bundles shall be provided separately to fill the cavity of NMEJ gap between Part-1 and 2 of dust trap.
 - ❖ Width of the part-2 shall be 350 mm.

Each part shall consist of flange reinforcement with KEB 1400 HT on either side.
Reference GA drawing of the same is attached herewith

Supervisory Service:

Supervisory services during installation and jointing of Dust trap shall be provided by supplier at free of cost for each quantity of NMEJ. GIPCL will intimate for the same in 7 days in advance.

Guarantee term:

Guarantee period shall be 18 months from the date of installation/commissioning of fabric at site or 24 months from the date of receipt of material at SLPP, GIPCL whichever is earlier.

Note: Sample of Dust trap is available at Site. Bidder may visit GIPCL-SLPP for further Clarification.

ANNEXURE- V

Technical specifications for NMEJ fabric at Cyclone to Flue gas duct inlet Item code no –710902043

1. The fabric selected for the expansion joint must withstand high temperature and pressure. It should withstand temperature up to 1100 °C and pressure +/- 300 mbar.
2. The fabric will consist of following layers or equivalent from outer to inner side.
One Layer of SS304 WM-0.44 mm Thick
One layer of specially treated Woven Texturised Glass Fabric (KEB 1300)-1.3 mm Thick
One layer of Skived Virgin PTFE -0.21 mm thick
One layer of Woven Texturised Glass fabric (KEB 700)-0.8 mm Thick
One layer of Needled Glass Felt – 9mm Thick
One layer of Super Wool 128 kg/m³ – 12 mm thick
One layer of High Silica 1250 Fabric -1.1 mm thick
FR: The flange reinforcement shall be done with Elastomer coated glass fabric on either side with Stapled.
3. Fabric must have proper gas sealing, strong end joints, better acid & weather resistance, higher strength & flexibility etc. (End points must have properties that they are to be joined by welding joint/heated joint & not by paste joint.)
4. Flange enforcement is to be provided on either side without hole punch.
5. The width of fabric is **350** mm and Length **17000** mm.(Please Refer attached drawing)
6. The outer & inner side of fabric must be clearly indicated on fabric at every 2 meter length.
7. The fabric selected must have sulphur & chlorine corrosion resistance.

Technical specifications for Insulation bolster at Cyclone to Flue gas duct inlet Item code no – 710902044

1. MOC of bolster will super wool of 128 Kg/m³ density encased with Special high temperature resistance glass fabric. The Bolster shall be covered with SS wire mesh 16x16, 0.44 mm thick and high silica 600 of 0.5 mm thick.
2. The bolster selected for the expansion joint must withstand high temperature and pressure. It should withstand temperature up to 1100 °C and pressure +/- 300 mbar.
3. An insulator bolster will have flange on both sides, of which the flanges will be bolted on the fabric fixing flange, below the main fabric.
4. The bolster selected shall match the fabric specifications as mentioned above.
5. **Length of the Bolster according to the Fabric length.**
6. Bolster shall be supplied in one piece without flange.

NOTE:

- 1) Fabric and bolster joining kit: Approx Qty: Needle: 01No, High Temp. Thread: 50 mtr, PTFE coil: 5 mtr, SS Wire: 15 mtr for each fabric and Bolster etc. shall be supplied with NMEJ.
- 2) Locking arrangement (Anchor) for bolsters & flange reinforcement of quantity: 300 Nos per bolster (L type anchor with Washer) shall be provided by party in separate box.
- 3) Fabric shall have corner bends & match with our existing arrangement.
- 4) Packing Slip shall be submitted with Supply of Material mentioning the quantity of material inside the BOX.

Supervisory Service:

- 5) Supervisory services during installation and jointing of fabric and bolster shall be provided by **supplier at free of cost** for each quantity of NMEJ. GIPCL will intimate for the same in 7 days in advance.

Guarantee term:-

Guarantee period shall be **18 months** from the date of installation/commissioning of fabric at site or **24 months** from the date of receipt of material at SLPP, GIPCL whichever is earlier.

2) PRICE BID FORMAT FOR SUPPLY OF NMEJ

Sr No	Item Code	Description	Qty in (No.)	Unit Rate (Rs.)	GST (%)	Landed Cost (Rs.)
1)	710106124	Dust Trap assembly for C To C NMEJ	7.00			
2)	710106107	BOLSTER 900 MM WIDTH 23.6M LONG FOR NMEJ	7.00			
3)	710106127	Dust Trap Clamping Bar - Corner	16.00			
4)	710106128	Dust Trap Clamping Bar-Straight L 2m	24.00			
5)	710106129	Dust Trap Clamping Bar-Straight L 1.2m	24.00			
6)	710902100	NMEJ FABRIC 500 MM WIDTH FOR B/P INLET	4.00			
7)	710902042	200THK, 200 WIDE BOLSTER 5236X5636	4.00			
8)	710902043	NMEJ TYPE FLEXZEN SPECIAL IN 330MM WIDE	6.00			
9)	710902044	100THK, 150MM WIDE BOLSTER DIA 4250 MM	6.00			
10)	710902060	NMEJ FABRIC 475 MM WIDE FOR CYCL TO SP	4.00			
11)	710902061	BOLSTER475MM WIDE FOR NMEJ AT CYCL TO SP	3.00			

TO BE SUBMITTED IN (N) CODE ONLY

All above prices shall be quoted through online (n)-Procure only; Hard copy of price bid shall not be considered/accepted.

SECTION-E

1.0 ANNEXURE-A

PROFORMA FOR BANK GUARANTEE FOR EARNEST MONEY DEPOSIT

(To be executed on non-judicial stamped paper of appropriate value)

B.G. No _____

Date : _

1. WHEREAS M/s.Gujarat Industries Power Company Limited having its Corporate Office at PO: RANOLI, Dist.Vadodara – 391 350, Gujarat State, India (hereinafter called “The Company Owner” which expression shall unless repugnant to the subject or context includes its legal representatives, successors and assigns) has issued tender paper vide its Tender No.....for -----
----- (hereinafter called “the said tender”) to M/s.(hereinafter called the said Tenderer(s)” which expression shall unless repugnant to the subject or context includes their legal representatives, successors and assigns and as per terms and conditions of the said tender, the tenderer shall submit a Bank guarantee for Rs..... (Rupeesonly) towards earnest money in lieu of cash.
2. WeBank having its branch office at do hereby undertake to pay the amount due and payable under this guarantee without any demur, merely on a demand from the Company stating that in the opinion of the company which is final and binding, the amount claimed is due because of any withdrawal of the tender or any material alteration to the tender after the opening of the tender by way of any loss or damage caused to or would be caused or suffered by the Company by reason of any breach by the said tenderer(s) of any of the terms and conditions contained in the said tender or failure to accept the letter of Intent Agreement or that the amount covered under this Guarantee is forfeited. Any such demand made on the Bank by the owner shall be conclusive as regards the amount due and payable by the Bank under this guarantee, However, our liability under this guarantee shall be restricted to an amount not exceeding Rs.....(Rupees.....only).
3. We undertake to pay to the Company any money so demanded not withstanding any dispute or disputes raised by the tenderer (s) in any suit or proceeding pending before any office, court or tribunal relating thereto our liability under this present guarantee being absolute and unequivocal. The payment so made by us under this bond shall be a valid discharge of our liability for payment there under. Our liability to pay is not dependent or conditional on the owner proceeding against the tenderer.
4. The guarantee herein contained shall not be determined or affected or suspended by the liquidation or winding up, dissolution or change of constitution or insolvency of the said tenderer(s) but shall in all respect and for all purposes be binding and operative until payment of all money due or liabilities under the said contract(s)/ Order(s) are fulfilled.
5. The Bank further unconditionally agrees with Gujarat Industries Power Company Limited (GIPCL) that Gujarat Industries Power Company Limited (GIPCL) shall be at liberty, without the Bank’s consent and without affecting in any manner the Bank’s obligation under this Guarantee, from time to time, to:
a. Vary and / or modify any of the terms and conditions of the Agreement.

- b. Extend and / or postpone the time for performance of the obligations of the Contractor under the Agreement.
- c. Forbear or enforce any of the rights exercisable by Gujarat Industries Power Company Limited (GIPCL) against the Contractor under the terms and conditions of the Agreement.
6. This guarantee shall be in addition to and not in substitution or in derogation of any other security held by Gujarat Industries Power Company Limited (GIPCL) to secure the performance of the obligations of the Contractor under the Agreement.
7. No action, event or condition, which by any Applicable Law should operate to discharge the Bank from liability hereunder, shall have any effect and the Bank hereby waives any right it may have to apply such law, so that in all respects its liability hereunder shall be irrevocable and, except as stated herein, unconditional in all respects.
8. WeBank Ltd. further agree that the guarantee herein contained shall remain in full force and effect during the period that would be taken for the finalization of the said tender and that it shall continue to be enforceable till the said tender is finally decided and order placed on the successful tenderer(s) and or till all the dues of the company under or by virtue of the said tender have been fully paid and its claims satisfied or discharged or till a duly authorized officer of the company certifies that the terms and conditions of the said tender have been fully and properly carried out by the said tenderer (s) and accordingly discharges the guarantee.
9. That the Owner Company will have full liberty without reference to us and without affecting this guarantee to postpone for any time or from time to time the exercise of any of the power of the owner under the tender.
10. Notwithstanding anything contained herein before, our liability shall not exceed Rs..... (Rupees.....only) and shall remain in force till..... (Date to be filled up shall be 180 days from the date of submission of Bid).

Date.....

..... Bank
 Corporate Seal of the Bank
 By its constitutional Attorney

Signature of duly Authorized person
 On behalf of the Bank

With Seal & Signature code

Bidder shall submit PBG from below mentioned banks only. Banks other than below mentioned list are not Allowed.

- All Nationalized Banks
- Axis Bank
- ICICI Bank
- HDFC Bank
- Kotak Mahindra Bank
- IndusInd Bank
- Federal Bank
- Bandhan Bank
- IDBI Bank
- Karur Vysya Bank

2.0 ANNEXURE-B

**PROFORMA FOR CONTRACT SECURITY-CUM-PERFORMANCE GUARANTEE
BY SELLER / CONTRACTOR.**

(To be executed on non-judicial stamped paper of approximate value)

B.G. No. _____

Date : ____

1. WHEREAS Gujarat Industries Power Company Limited having its office at PO: RANOLI, Dist. Vadodara – 391 350, Gujarat State, India (hereinafter referred to as “The Company/Owner” which expressions shall unless repugnant to the subject or context includes its legal representatives, successors and assigns) has entered into a contract with M/s. / has placed a purchase order on M/s.....(hereinafter referred to as “Contractor(s)/ Seller(s)” which expression shall unless repugnant to the subject or context includes their legal representatives, successors and assigns) foron the terms and conditions as set out inter alia, in the Company’s contract No./ P.O.No.....dateand various documents forming part thereof hereinafter referred to as the “said contract” which expression include all amendments, modifications and/ or variations thereto and where as the Contractor(s)/ Seller(s) has agreed for due execution of the entire contract and guarantees its performance including any parts executed through any other agencies/ subcontractors

AND WHEREAS one of the conditions of the “said contract” is that “contractor(s)/seller(s) shall furnish to the owner a Bank Guarantee from a bank for% (.....percent) of the total value of the “said contract” against due and faithful performance of the “said contract” including performance guarantee obligations of the contractor(s)/seller(s) for execution/ supplies made under the “said contract.”

2. WeBank having its branch office atdo hereby agree and undertake to pay the amount due and payable under this guarantee without any demur merely on a demand from the Company stating that in the opinion of the Company, which is final & binding, the amount claimed is due by reason of default made by the Contractor(s)/ Seller(s) in performing any of the terms & conditions of the said Contract including defect liability obligations, in fulfilling the performance guarantee obligation or loss or damage caused to or would be caused to or suffered by the Company by reason of any breach by the said Contractor (s)/ Seller(s) of any of the terms & conditions of the contract. Any such demand made on the Bank by the owner shall be conclusive as regards the amount due and payable by the Bank under this guarantee. However our liability under this guarantee shall be restricted to Rs.(Rupees.....only).



3. We undertake to pay to the Company any money so demanded notwithstanding any dispute or disputes raised by the contractor(s)/ Seller(s) in any suit or proceeding pending before any office, court or tribunal relating thereto our liability under this present guarantee being absolute and unequivocal. The payment so made by us under this bond shall be a valid discharge of our liability for payment there under. Our liability to pay is not dependent or conditional on the owner proceeding against the Contractor(s)/ Seller(s).
4. The guarantee herein contained shall not be determined or affected or suspended by the liquidation or winding up, dissolution or change of constitution or insolvency of the said Contractor(s)/ Seller(s) but shall in all respect and for all purposes be binding and operative until payment of all money due or liabilities under the said contract(s)/ Order(s) are fulfilled.
5. The Bank further unconditionally agrees with Gujarat Industries Power Company Limited (GIPCL) that Gujarat Industries Power Company Limited (GIPCL) shall be at liberty, without the Bank's consent and without affecting in any manner the Bank's obligation under this Guarantee, from time to time, to:
 - a. Vary and / or modify any of the terms and conditions of the Agreement.
 - b. Extend and / or postpone the time for performance of the obligations of the Contractor under the Agreement.
 - c. Forbear or enforce any of the rights exercisable by Gujarat Industries Power Company Limited (GIPCL) against the Contractor under the terms and conditions of the Agreement.
6. This guarantee shall be in addition to and not in substitution or in derogation of any other security held by Gujarat Industries Power Company Limited (GIPCL) to secure the performance of the obligations of the Contractor under the Agreement.
7. No action, event or condition, which by any Applicable Law should operate to discharge the Bank from liability hereunder, shall have any effect and the Bank hereby waives any right it may have to apply such law, so that in all respects its liability hereunder shall be irrevocable and, except as stated herein, unconditional in all respects.
8. This guarantee will remain valid up _____ days or _____ whichever is earlier. The Bank undertakes not to revoke this guarantee during its currency without previous consent of the OWNER/PURCHASER and further agrees that if this guarantee is extended for a period as mutually agreed between bidder & owner/purchaser, the guarantee shall be valid for a period so extended provided that a written request for such extension is received before the expiry of validity of guarantee.
9. WeBank further agree with the Company that the company shall have the fullest liberty without our consent and without affecting in any manner our obligations hereunder to vary any of the terms and conditions of the said Contract(s)/ Order(s) or to extend the time of performance by the said Contractor(s) Seller(s) from time to time or to postpone for any time or from time to time any of the powers exercisable by the Company against the said Contractor(s)/ Seller(s) and to forbear or enforce any of the terms and conditions relating to the said Contract(s)/ Order(s) and



we shall not be relieved from our liability by reason of any such variation, or extension being granted to the said Contractor (s) / Seller(s) or for any forbearance, act or omission on the part of the Company or any indulgence by the Company to the said Contractor(s)/ Seller(s) or by any such matter or thing whatsoever which under the law relating to sureties would, but for this provision, have affect of so relieving us.

10. Notwithstanding anything contained herein before, our liability shall not exceed Rs.....(Rupees.....only) and shall remain in force till.....Unless a demand or claim under this Guarantee is made on us within three months from the date of expiry we shall be discharged from all the liabilities under this guarantee.

Date.....

Corporate Seal of the Bank

.....Bank
By its constitutional Attorney
Signature of duly Authorized
person
On behalf of the Bank
With Seal & Signature code

Note: BGs to be furnished from any of the banks listed at Annexure -VI of Volume I.

Bidder shall submit BG from below mentioned banks only. Banks other than below mentioned list are not Allowed.

- All Nationalized Banks
- Axis Bank
- ICICI Bank
- HDFC Bank
- Kotak Mahindra Bank
- IndusInd Bank
- Federal Bank
- Bandhan Bank
- IDBI Bank
- Karur Vysya Bank



3.0 ANNEXURE-C

Schedule of Deviation from Technical Specification and Commercial Terms and Conditions

All the deviations from the terms & conditions of contract shall be filled by BIDDER clause by clause in this schedule.

Sr. No	SECTION	CLAUSE NO	AS PER TENDER DOCUMENT	DEVIATION
COMPANY SEAL				
SIGNATURE-----				
NAME-----				
DESIGNATION---				
COMPANY----				
DATE ----				

The bidder here by certifies that the above mentioned are the only deviations from OWNER's Tender enquiry. The bidder further confirms that in the events any other data and information presented in the BIDDER's proposal and accompanying documents are at variance with specific requirements laid out in the OWNER's Tender Document, then the latter shall govern and will be binding on the BIDDER for quoted price.



4.0 ANNEXURE- D

Declaration for Contractual Litigations

(To be submitted on Company's Letter Head)

Please Tick (√) whichever is correct option

I _____ on behalf ofName of Party/Company.....hereby confirm that I /We have

- a. Not invoked legal recourse e.g. litigation against any Govt, of Gujarat Undertakings / Depts. / Authorities and Govt. of Gujarat supported companies / undertakings / organizations for the last three(03) years. There are no ongoing/pending legal matter(s) with any of the Govt. of Gujarat Undertakings / GoG supported Companies, including GIPCL.

Please Tick()

OR

- b. Invoked legal recourse e.g. litigation against any Govt, of Gujarat Undertakings / Depts. / Authorities and Govt. of Gujarat supported companies / undertakings / organizations for the last three(03) years.

Please Tick()

If “b” is applicable, please submit the details for the same.

The above is true, as on date, to the best of my knowledge. Any breach/ false statement in this regard shall amount to disqualification of the Bid being submitted herein.

Signed and Stamped by the
Authorized Signatory
Of the Bidder



5.0 ANNEXURE- E

PARTICULARS OF THE BIDDER

Sr. No.	Particulars	Please provide information here.
1.	Name of Bidder	
2.	a. Registered Office Address: b. Address for Correspondence: c. E-mail ID:	
3.	Contact Details: Contact Person Name Telephone No. : Mobile No.:	
4.	Year of establishment PAN No. GST No	

COMPANY SEAL

SIGNATURE

NAME

DESIGNATION

COMPANY

DATE



6.0 ANNEXURE- F

PROCEDURE FOR MAKING ONLINE PAYMENT OF EMD/TENDER FEE

1. For making online payment, first go to the website: www.gipcl.com
2. Then, click on the caption/link as can see like:
“Click here for Making Online Payment of EMD/SD, Advance for Ash, DM water etc.”
(The link is visible as horizontal highlighted below Tenders - News & Update Section.)
3. After clicking the link the new page will open. On this page, No need to enter User Name and Password. Directly click on “ Payment Form” given below the sign in option.
4. After clicking the “Payment Form”, the vendor has to enter the details asked which will be self explanatory. It is desired that all the information may be filled correctly so that the payment made can be tracked.

If the some required fields are not known/available, vendor may write “Not Available” and then proceed. E.g. some information like Party code is not available to vendor or GST No. not available with vendor.

Optional Note: Although mentioned as above can be proceeded with “Not available”, It will be appreciated that regular vendors may obtain the party code, so that the vendor can be identified. The same party code may be used for future transactions also. After entering the details, click on SUBMIT Button.

5. The vendor/Party will be redirected to Payment Gateway. By selecting the desired payment mode, payment can be made:
6. After making the payment, the receipt will be generated which has to be submitted with technical bid.

Important Note: Please note that for making online payment through the above gateway, the charges* as below will be applicable, which has to be borne by Vendor/Party making the Payment:

Payment Mode	Charges
Net Banking	Rs.9 + GST
Debit Card	NIL
Credit Card	0.75% + GST
International Card	3.00% + GST
UPI	NIL

Corner base

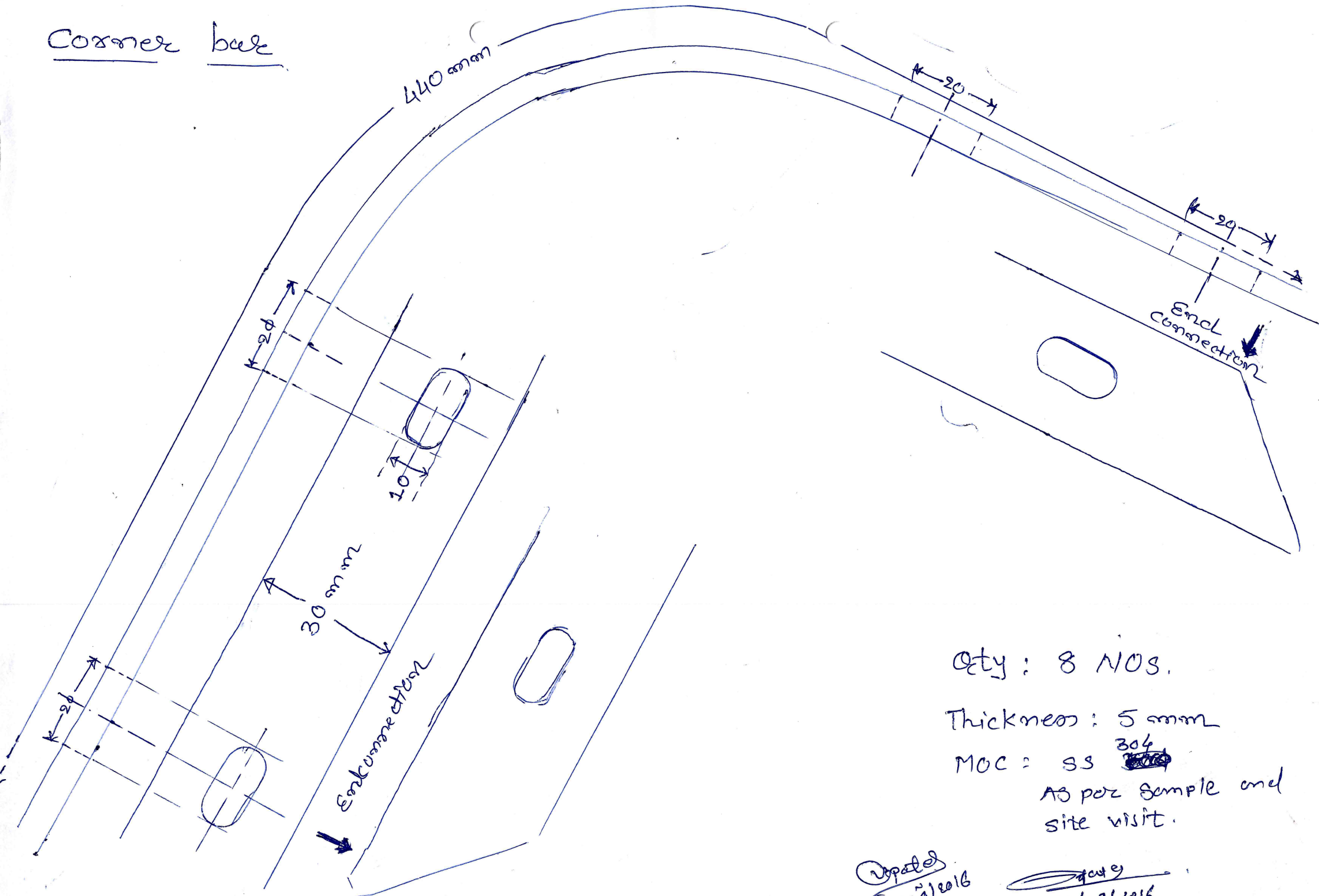

Qty : 8 NOS.

Thickness : 5 mm

MOC : SS ³⁰⁴ ~~304~~
As per sample and site visit.

Upad
01/09/2016

Upad
01/09/2016

Dust Trap:

- ① Straight Bars
MOC = SS 304
(As per Sample)

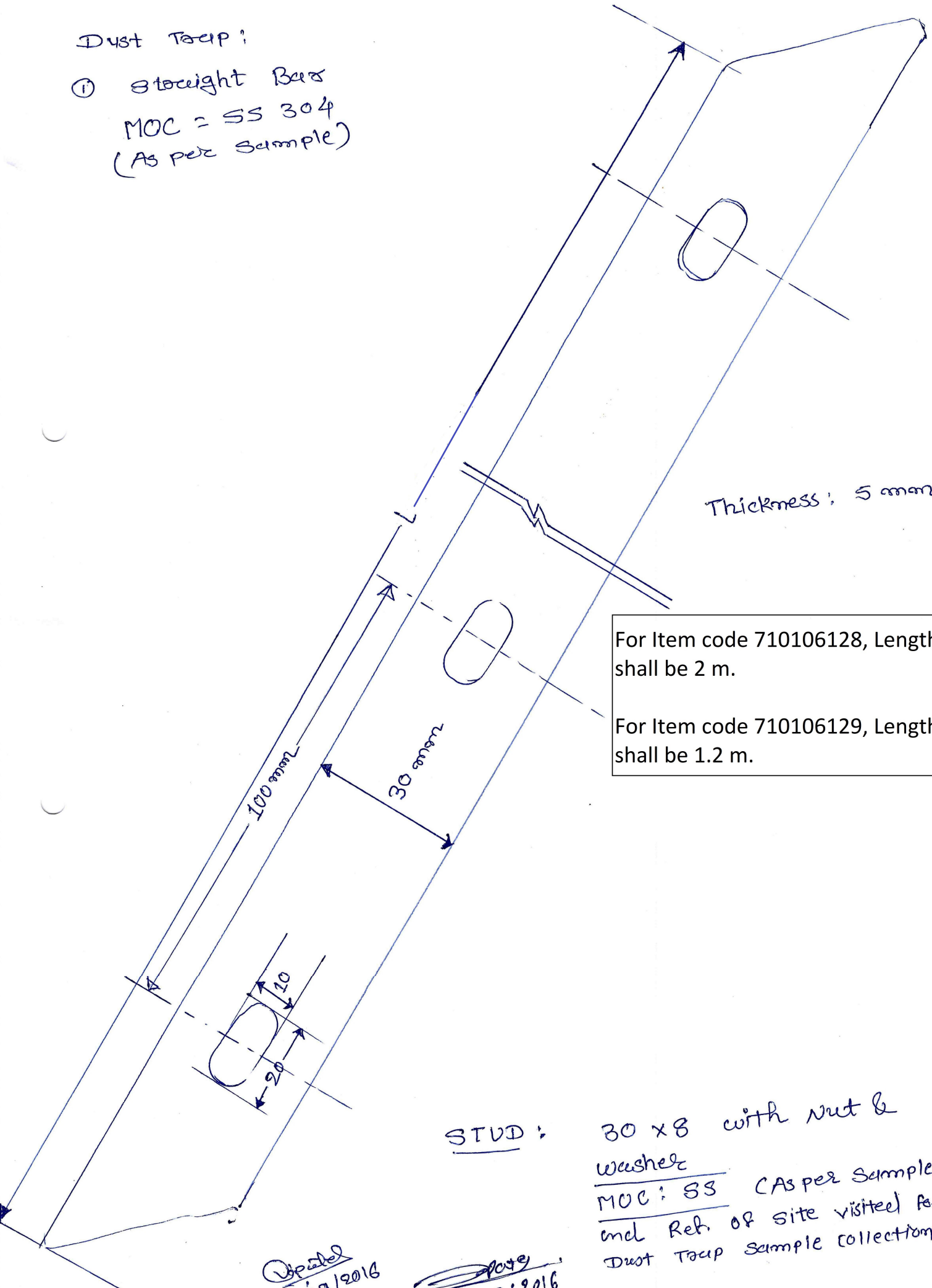

Thickness: 5 mm

For Item code 710106128, Length (L) shall be 2 m.
For Item code 710106129, Length (L) shall be 1.2 m.

STUD: 30 x 8 with nut & washer
MOC: SS (As per Sample)
incl Ref. of site visited for Dust Trap sample collection)

Updated
11/09/2016

01/09/2016

This document and all information thereon is the property of KE-BURGAMANN. It must not be copied, imparted to a third party or used for any other purpose without the consent of KE-BURGAMANN.

SL. No	Tag No	Fabric Type	Qty	Temp °C	PRSS mmWC	Movements		L	S	R	Fabric length	Location
						Ax	Lat					
03	EJ-03	Flexgen-SPL	2	1000	-	-	-	350	530	155	10000	Between Cyclone & seal port
04	EJ-04	Flexgen-SPL	2	1000	-	-	-	350	500	200	26500	Flue gas duct to back pass

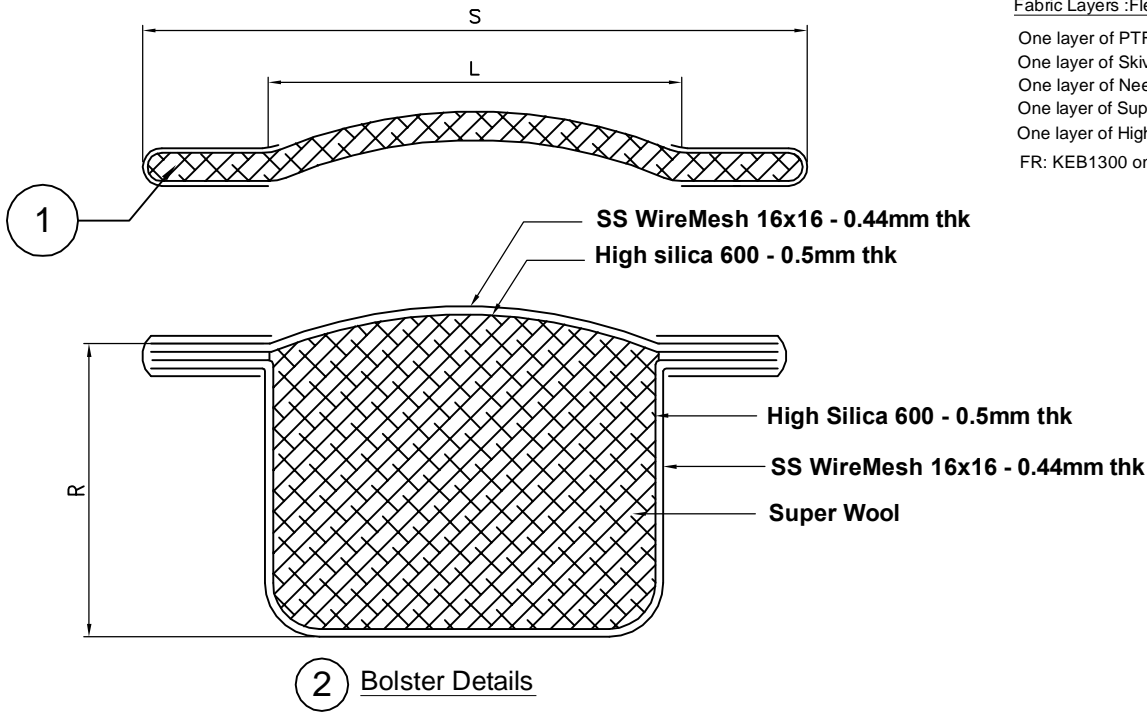

Fabric Layers :Flexgen - SPL(From Outer to Inner)

- One layer of PTFE coated & both side laminated Glass fabric - 0.95mm thk.
- One layer of Skived Virgin PTFE - 0.21mm thk
- One layer of Needled Glass felt - 9mm thk.
- One layer of Super wool 128kg/m3 - 12mm thk
- One layer of High silica 1250 fabric - 1.1mm thk
- FR: KEB1300 on either side - 1.3mm thk.

KEB Scope:- Fabric & Bolster only
Fabric to be supplied in open belt condition without holes punched.

NOTES:- # All Dimensions are in mm # Only dimensional & visual check applicable on finished material.							CUSTOMER : Gujarat Industries Power company Ltd.					
							PROJECT : Surat Lignit Power Project					
							P.O.NUMBER: -				DRG. NO.	KEB.TS.784M.03
											REV.NO.	00
							GA DRAWING OF NON METALLIC EXPANSION JOINT					
							DATE:	10/01/2011				
							REF NO.	TS-784M				
				2	Bolster	Ref.type	KEB Scope	CHECKED	APPROVED	SCALE		
				1	KEB Fabric	Ref.type	KEB Scope	RRK	AN	NTS		
00	10/01/2011	NJS	-	PART NO.	DESCRIPTION	MATERIAL	REMARKS					
REV. NO.	DATE	REV. BY	PARTICULARS									

S.No.	Tag No	Fabric Type	Qty	Temp	Pressure mmWC	Axial	Lateral	Location
01	--	Flexgen SPL	2	1000°C	+1020 / -510	10	130	Cyclone Inlet

Fabric Layers : (From Inner to Outer)

Flexgen SPL:

- One layer of KEB 1400 HT
- One layer of KEB 1300
- One layer of CS Lambda Blanket
- One layer of PTFE
- One layer of KEVLAR
- One layer of CL PTFE
- FR: Alusil

'U' Type Bolster:

- One layer of SSWM
- One layer of KEB 1400 HT
- One layer of Super Wool (128 Kg/m3) - 50 mm thk
- One layer of KEB 1400 HT
- One layer of SSWM

1st part

Dust Trap with Bolster:

- One layer of SS310 HDWM
- One layer of HS 1250
- Insulation of Super wool (128 Kg/m3)
- One layer of HS 1250
- One layer of Incoloy WM
- FR: KEB 1400 HT

2nd part

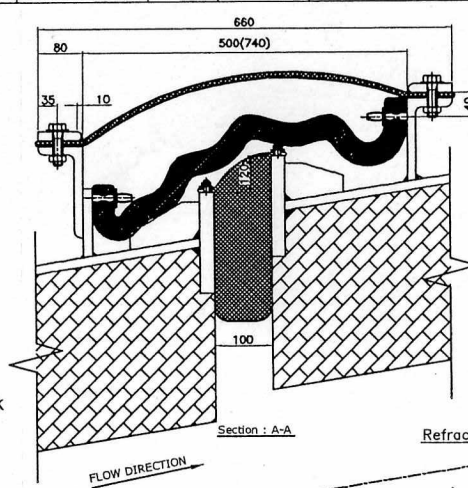

Refractory by BHEL

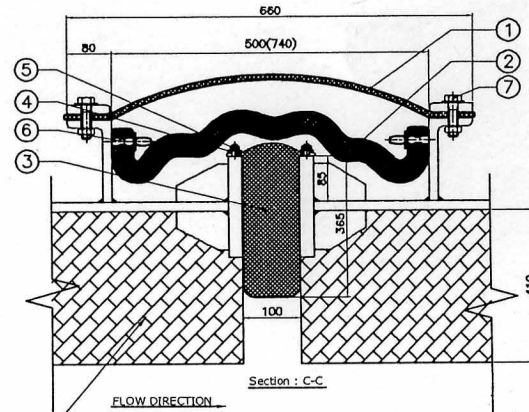

View in Flow Direction on Fabric path

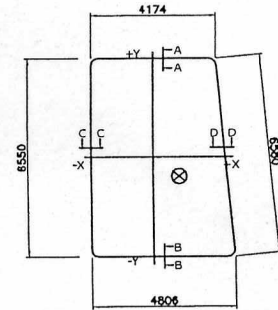

Fabric length : 23000

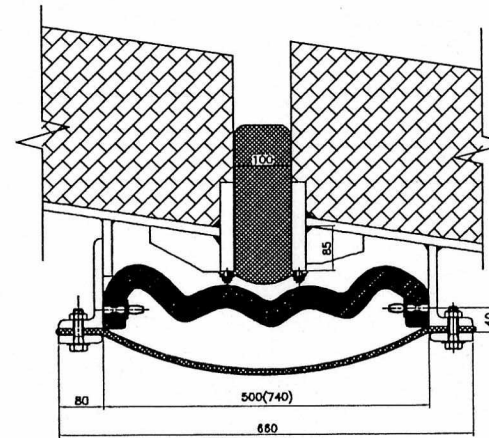
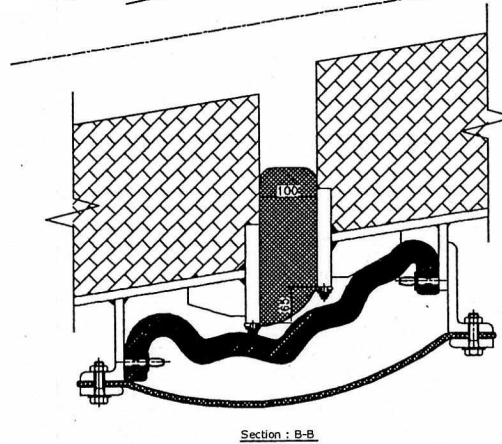

General Notes :-

- # All Dimensions are in mm
- # Welding at site to be done as per Drg. No: KEB.DWJ.1001.01

CUSTOMER : GIPCL

PROJECT : SLPP

P.O.NUMBER: -

GA DRAWING OF NON METALLIC EXPANSION JOINT

DATE: 21.05.2011
REF NO. TS-894B

CHECKED: RNR
APPROVED: RRK
SCALE: NTS

REV. NO.	DATE	REV. BY	PARTICULARS
00	21.05.2011	RNR	--

PART NO.	DESCRIPTION	MATERIAL	REMARKS
7	Fabric Fixing Fasteners	M20x60 Gr. 8.8 (~ 650 nos)	
6	Speed Clip	SS 304 (~ 575 nos)	
5	Stud (with Nut & washer)	M8x30, Gr.8.8 (~ 825 nos)	
4	Dust Trap Clamping Bar	IS 2062 Gr.A/B (32x6) - 4 nos	
3	Dust Trap with Bolster	Ref.type	
2	'U' Type Bolster	Ref.type	
1	KEB Fabric	Ref.type	

This document and all information thereon is the property of KE-BURGAMANN. It must not be copied, imparted to a third party or used for any other purpose without the consent of KE-BURGAMANN.

SL. No	Tag No	Fabric Type	Qty	Temp °C	PRSS mmWC	Movements		L	S	R	Fabric length	Location
						Ax	Lat					
02	EJ-02	KEB-SPL	2	1000	-	-	-	200	350	100	17000	Between Cyclone & flue gas duct

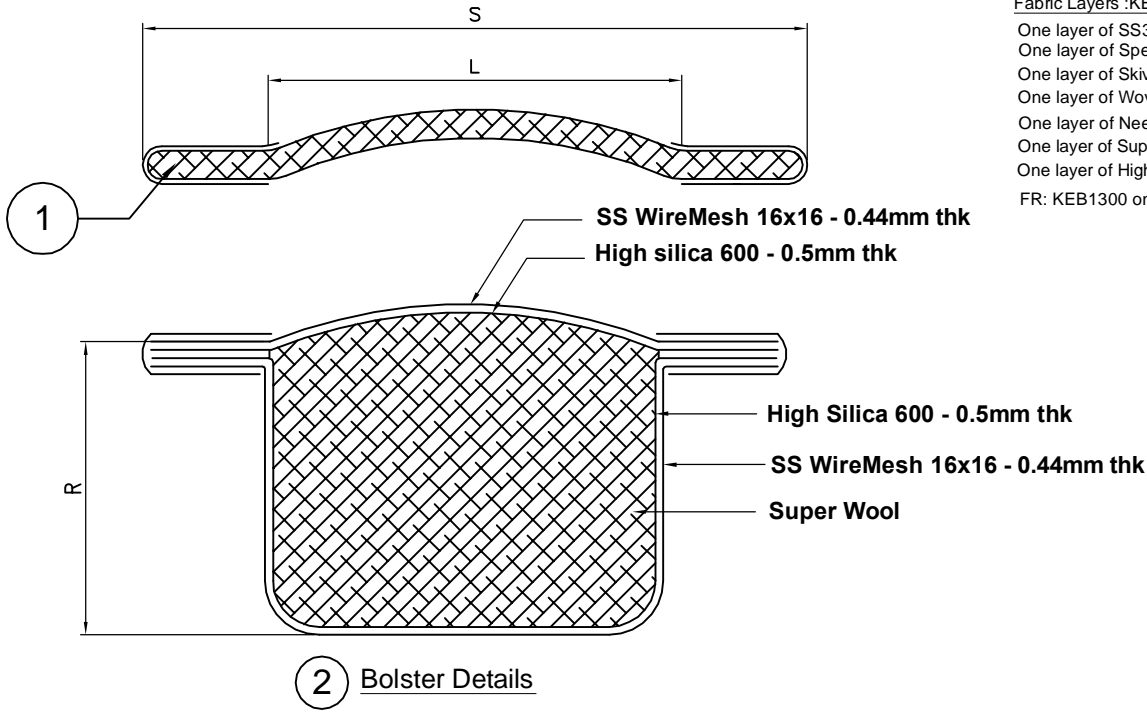

Fabric Layers :KEB - SPL(From Outer to Inner)

- One layer of SS304 WM - 0.44 mm thk.
- One layer of Specially Treated Woven Texturised Glass fabric(KEB 1300) - 1.3mm thk.
- One layer of Skived Virgin PTFE - 0.21mm thk
- One layer of Woven Texturised Glass fabric(KEB 700) - 0.8mm thk
- One layer of Needled Glass felt - 9mm thk.
- One layer of Super wool 128kg/m3 - 12mm thk
- One layer of High silica 1250 fabric - 1.1mm thk
- FR: KEB1300 on either side - 1.3mm thk.

KEB Scope:- Fabric & Bolster only
Fabric to be supplied in open belt condition without holes punched.

NOTES:- # All Dimensions are in mm # Only dimensional & visual check applicable on finished material.								CUSTOMER : Gujarat Industries Power company Ltd.			
								PROJECT : Surat Lignit Power Project			
								P.O.NUMBER: -		DRG. NO.	KEB.TS.784M.02
										REV.NO.	00
								GA DRAWING OF NON METALLIC EXPANSION JOINT		DATE:	10/01/2011
										REF NO.	TS-784M
				2	Bolster	Ref.type	KEB Scope	CHECKED	APPROVED	SCALE	
				1	KEB Fabric	Ref.type	KEB Scope	RRK	AN	NTS	
REV. NO.	DATE	REV. BY	PARTICULARS	PART NO.	DESCRIPTION	MATERIAL	REMARKS				