



**TENDER FOR PROCUREMENT OF BEND PIPE FOR REHEATER LINK  
(Bid No.: GIPCL/MATLS/BEND PIPE/2019-20)**

**GUJARAT INDUSTRIES POWER COMPANY LIMITED**

**TENDER FOR PROCUREMENT OF BEND PIPE FOR REHEATER LINK**

**Bid No.: GIPCL/MATLS/BEND PIPE/2019-20**

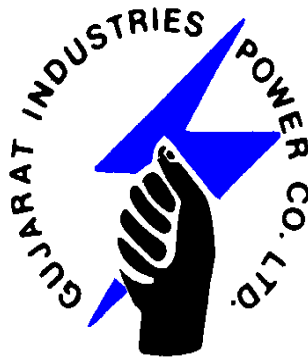

**INSTRUCTIONS TO BIDDERS & CONDITIONS OF  
CONTRACT**



**TENDER FOR PROCUREMENT OF BEND PIPE FOR REHEATER LINK  
(Bid No.: GIPCL/MATLS/BEND PIPE/2019-20)**

**INDEX**

<b><u>Sr. No.</u></b>	<b><u>PARTICULARS</u></b>	<b><u>PAGE NO.</u></b>	
		<b>From</b>	<b>To</b>
<b>(1)</b>	<b><u>NOTICE INVITING TENDER (NIT)</u></b>	<b>03</b>	<b>04</b>
<b>(2)</b>	<b><u>SECTION – A</u> (Instructions to Bidders)</b>	<b>05</b>	<b>13</b>
<b>(3)</b>	<b><u>SECTION– B</u> (Instructions to Bidders for online tendering)</b>	<b>14</b>	<b>15</b>
<b>(4)</b>	<b><u>SECTION – C</u> (General Conditions of Contract)</b>	<b>16</b>	<b>20</b>
<b>(5)</b>	<b><u>SECTION – D,</u> (Technical Details &amp; Price Bid Schedule)  Price Schedule, Technical Specifications &amp; Terms &amp; Conditions, Drawing</b>	<b>21</b>	<b>23</b>
<b>(6)</b>	<b><u>SECTION – E</u> (Annexure and Forms)  Annexure-A – Proforma for BG for EMD, Annexure-B - Proforma for BG for PBG, Annexure-C Deviation Sheet, Annexure-D Declaration for Contractual Disputes, Annexure-E Vendor Details</b>	<b>24</b>	<b>31</b>



**TENDER FOR PROCUREMENT OF BEND PIPE FOR REHEATER LINK  
(Bid No.: GIPCL/MATLS/BEND PIPE/2019-20)**

**NOTICE INVITING TENDER (NIT)  
TENDER NO.: GIPCL/MATLS/BEND PIPE/2019-20)**

Name of work	PROCUREMENT OF BEND PIPE FOR RE-HEATER LINK
Place of Supply	GUJARAT INDUSTRIES POWER CO. LTD,  Surat Lignite Power Plant (SLPP) At & Post: Nani Naroli Taluka: Mangrol Dist: Surat pin: 394112 (Gujarat)
Quantity	Quantity Of Bend Pipes Are 02 No And Technical Details Are as per Section-D.
EMD	<b>Rs. 50,000/- (Rs. Fifty Thousand only) as per clause No.06 of Section A.</b>
Security Deposit	10% of Basic Order Value (excluding Taxes & Duties) from any Schedule Public Sector Bank or Schedule Private Sector Bank in favour of Gujarat Industries Power Company Ltd as per Clause No.01 of Section C, GCC.
Availability of online Tender document	Tender will be available on (n) Procure from <b>08.08.2019</b>
Last date of online submission of offer	<b>29.08.2019, 17:30</b> hrs. on (n) Procure
Submission of EMD and other supporting documents for technical Bid in physical form	On or before due date at office of GIPCL, P.O. Petrochemical – 391346 Dist.: Vadodara, Gujarat – India



**TENDER FOR PROCUREMENT OF BEND PIPE FOR REHEATER LINK  
(Bid No.: GIPCL/MATLS/BEND PIPE/2019-20)**

**NOTES:**

1. Amendment / corrigendum of the tender document, forms, schedules, etc... may be done any time by the GIPCL during the period of publication of Tender in the website. The Bidders are required to visit the website regularly till the last date & time of Bid submission.
2. GIPCL reserves the right to reject any or all the tenders without assigning any reason thereof.
3. The Bidders are required to quote the rate strictly as per the terms and conditions mentioned in the tender document, adhering to technical specifications as well.
4. The Bidders are required to submit their Bids online through the website [www.nprocure.com](http://www.nprocure.com).
5. The EMD & other supporting documents are to be submitted in physical form only at the following address:-

**Addl. General Manager (Materials & Contracts)  
Gujarat Industries Power Company Limited,  
P.O. Petrochemical – 391346  
Dist.: Vadodara.**



**TENDER FOR PROCUREMENT OF BEND PIPE FOR REHEATER LINK  
(Bid No.: GIPCL/MATLS/BEND PIPE/2019-20)**

**SECTION-A**  
**INSTRUCTIONS TO BIDDERS**

**1. PLANT SYNOPSIS**

GIPCL (the “Company”) was incorporated in 1985 as Public Limited Company and engaged in Business of Electrical Power Generation. The total present capacity of Vadodara (310 MW Gas based + 1 MW Solar+112.4 MW Wind), Mangrol (500 MW Lignite based + 5 MW Solar + 1 MW Solar) and Gujarat Solar Park (80 MW Solar) plants is 1009.4 MW. The company is having its registered office at P.O. Petrochemical, Vadodara, Gujarat.

The Company commissioned first power project; a 145 MW gas based Combined Cycle Power Plant in February, 1992 at Vadodara. The Company expanded its capacity and commissioned 165 MW Naphtha & Gas based Combined Cycle Power Plant at Vadodara in November, 1997 as Independent Power Producer (IPP) with Power Purchase Agreement (PPA) with GUVNL.

GIPCL commissioned 250 MW (SLPP Phase-I : 2x125 MW) Lignite based Power Plant at Village: Nani Naroli, Taluka: Mangrol, District: Surat in November, 1999 as Independent Power Producer (IPP). The Company also has its own Captive Lignite Mines at Vastan, Mangrol & Valia for Surat Lignite Power Plant. Further, SLPP Phase-II: 2 x 125 MW has been commissioned in April 2010.

Surat Lignite Power Plant (SLPP) is accessible by road from Kim and Kosamba, which are on Mumbai-Ahmadabad highway. From Kosamba, SLPP is around 32 KM, out of which 27 KM is part of the National & State Highway and balance 5 KM is District Road. From Kim, SLPP is around 18 KM, out of which 13 KM is the State Highway and balance 5 KM is District Road. The nearest Broad Gauge Railway Line is at Kim, which is around 21 KM from the SLPP. Surat is approximately 50 KM from the SLPP.

**2. SCOPE OF SUPPLY:**

Detail Scope of Supply, Technical Specifications, and Quantities for Procurement of Bend Pipe for Reheater Link is mentioned in Section-D.

**3. GENERAL INSTRUCTIONS**

- 3.1 The Bidders who are interested in participating in the tender must read and comply with the instructions and the Terms & Conditions contained in the tender documents.
- 3.2 The Bids shall be filled in by the Bidders clearly, neatly and accurately. Any alteration, erasures or overwriting shall be liable to make the tender invalid unless the same is neatly carried out and attested over the full signature of Bidder. The decision of the Company to interpret the information and rates filled in by the Bidder shall be final and binding on the Bidder.



## **TENDER FOR PROCUREMENT OF BEND PIPE FOR REHEATER LINK (Bid No.: GIPCL/MATLS/BEND PIPE/2019-20)**

- 3.3 The Bidders are requested to make themselves fully conversant with the General Conditions of Contract, Technical Specifications, etc. before submitting their bids so that no ambiguity arises in these respects subsequent to submission of the Bids.
- 3.4 Bidder has to submit all the information as per required Bid document. Failure to furnish all the information as per required Bid documents shall be rejected.
- 3.5 The Bids shall be submitted within the time frames set out in the Notice Inviting Tender ('NIT') and Bids submitted thereafter shall not be accepted and considered.
- 3.6 The tender documents shall not be transferable.
- 3.7 The Bidders are expected to examine all instructions, forms, terms & specifications in the Bid documents and to get fully acquainted themselves with all the conditions and matters which may affect the subject matter of the tender or the cost thereof. If any Bidder finds any discrepancies or omissions in the specifications and documents or any doubt in true meaning or interpretation of any part, he shall seek necessary clarifications in writing if required prior to due date of tender.
- 3.8 Conditional offers shall not be considered and liable to be rejected.
- 3.9 The Company reserves the right to extend the deadlines for submission of the Bids by giving amendments.
- 3.10 During evaluation of Bids the Company may, at its discretion ask the Bidder (s) for clarification of their Bid. The request for clarification and the response shall be in writing and no change in prices or substance of the Bid shall be sought, offered or permitted.
- 3.11 The Company reserves the right to amend/ modify the Bidding documents at any time prior to the deadline for submission of Bids, either at its own discretion or in response to the clarification requested by a prospective Bidder. In such case, the Company may in its discretion extend the deadline for submission of Bids in order to facilitate the prospective Bidders for incorporating the effect of the amendment in their Bids.
- 3.12 The Company reserves the right to qualify/disqualify any applicant without assigning any reason.
- 3.13 If the successful Bidder is a joint venture, formed of two or more companies, the Bidder along with the partners shall accept joint and several responsibilities and liabilities for all obligations under the Contract.
- 3.14 Timely and satisfactory completion of the work and strict adherence to the allotted time frames for jobs shall be the essence of the contract.
- 3.15 The Bidder shall be disqualified if any untrue statement or misrepresentation is made in the Bid forms, attachments and other supporting documents submitted by the Bidder.
- 3.16 The Bidders shall bear all costs and expenses associated with the preparation and submission of their respective Bids, to attend meetings or conferences, if any, including any pre award discussion with the successful Bidder, technical and other presentations etc. and the Company shall not be liable for any expense thereof.



## TENDER FOR PROCUREMENT OF BEND PIPE FOR REHEATER LINK (Bid No.: GIPCL/MATLS/BEND PIPE/2019-20)

### 4. ELIGIBILITY CRITERIA

The following criteria shall be adopted for qualifying the Bidders for further proceeding.

- 4.1 Bidder should be a Manufacturer of Seamless Alloy Steel Bends (Well known tube maker as per IBR) or an authorized dealer of manufacturer of Alloy Steel Seamless Bends (Well known tube maker as per IBR). Bidder shall submit authorized dealership certificate from their manufacturer.
- 4.2 Bidder should have supplied Alloy Steel Seamless Bends. Bidder shall submit Purchase Order Copy of Alloy Steel Seamless Bends in their name supplied to any Govt/PSU/IPP/Pvt Company within last five years. Bidder who has supplied bends of size OD 609.6 mm, thickness 30 mm and MOC ASME SA 335 Grade P22 will be preferable. Following PO copies are required.
- a. One PO Copy of required material each costing not less than the amount equal to Rs. 24 Lacs.
- OR
- b. Two PO Copy of required material each costing not less than the amount equal to Rs. 15 Lacs.
- OR
- c. Three PO Copy of required material each costing not less than the amount equal to Rs.12 Lacs
- 4.3 Bidder shall submit necessary evidence for the same like attested copies of Purchase Orders, Successful Supply/Material Acceptance Certificates/performance certificates from clients.
- 4.4 The Bidder should have minimum average turnover of **Rs. 1.00 Crore** per annum during last three financial years. Balance Sheet of the company along with profit and loss account to be submitted duly audited by chartered accountant. The Balance sheet must be in the name of the Company who is purchasing the tender document any type of MOU for this purpose shall not be entertained. Net Worth of bidder shall be positive.
- 4.5 EMD: The EMD of Rs. 50,000/- shall be accompanied in the form of DD or Bank Guarantee given by Bank as described in subsequent clause.
- 4.6 The Bidder has to submit INCOME TAX Permanent Account Number (PAN), GST Registration No of the firm. Copies of the same shall be submitted.
- 4.7 All the tender documents shall be submitted with sign and stamp on each & every page.

Attested copies of relevant documents asked shall be submitted with duly signed & seal on each & every. The above documents will be analyzed and after satisfaction, the



## **TENDER FOR PROCUREMENT OF BEND PIPE FOR REHEATER LINK (Bid No.: GIPCL/MATLS/BEND PIPE/2019-20)**

Price Bid will be open. GIPCL may verify the documents, experience certificates issued by concern authority. After opening of technical Bid, if any required attested documents found missing in the Technical Bid submitted by the Bidder, the tender inviting authority may inform to that Bidder only once by E-mail to submit the missing required documents within stipulated time limit. If Bidder/Bidders fail to submit within stipulated time, their Bid will be declared technically disqualified and no further correspondence will be entertained.

The Bidder shall submit all the evidences, documents, attested copies of purchase orders etc as a proof with EMD and also provide the requisite details online for meeting the prequalification requirements. GIPCL will verify the experience, performance, capability & strength of Bidders, independently for executing the job. GIPCL may visit the site & consult the owner of the industry/property where similar job is executed by the Bidder. GIPCL reserves the right to accept/cancel/reject any/all Bids without assigning any reason thereof. The tenders of qualified Bidder/Bidders shall only be considered for further evaluation.

- 4.8** If Bidder or its Partner(s) or Director(s) is /are/was in any Litigation(s), Court Case(s) or Arbitration(s), either completed or under progress during last five (5) years or Black Listed / Deregistered / Stopped or banned from dealing in the past by any Govt, of Gujarat Undertakings / Depts. / Authorities and Govt. of Gujarat supported companies / undertakings / organizations, Bid of that bidder will be liable to be rejected. Bidder agrees and undertakes to accept decision of GIPCL in this regards as final and binding on the Bidder without any demur and that no further correspondence shall be done in this regard at any stage.

### **5. LANGUAGE OF BID**

The Bid prepared by the Bidder, and all correspondence and documents relating to the Bid exchanged by the Bidder and the Company, shall be written in the English language. Any printed literature furnished by the Bidder, written in another language shall be accompanied by an English translation for the purpose of interpretation of the Bid.

### **6. EARNEST MONEY DEPOSIT (EMD)**

- 6.1** An EMD of Rs. 50,000/- and shall accompany with Bid. The EMD shall be in the form of a crossed bank Demand Draft in favor of Gujarat Industries Power Co. Ltd. **and payable at Vadodara.**
- 6.2** The EMD, in alternative, may be submitted in the form of irrevocable Bank Guarantee in favor of Gujarat Industries Power Company Limited from any Schedule Public Sector Bank or Schedule Private Sector as per Performa of BG enclosed under Section-E.
- 6.3** In case EMD is paid in the form of BG, the same shall be valid for a period of 180 days after the due date for submission of the bid.





## TENDER FOR PROCUREMENT OF BEND PIPE FOR REHEATER LINK (Bid No.: GIPCL/MATLS/BEND PIPE/2019-20)

- 6.4 The EMD of the Successful bidder will be returned after payment of Security Deposit by successful bidder.
- 6.5 The earnest money deposit paid in the form of Demand draft/BG will be refunded to the Unsuccessful BIDDER as soon as the tender is finalized.
- 6.6 Any bid not accompanied with EMD will be rejected. EMD should be submitted in physical form directly to GIPCL.
- 6.7 No interest shall be payable on EMD.
- 6.8 The EMD will be forfeited if the BIDDER (i) withdraws his tender after acceptance or (ii) withdraws his tender before the validity date of the tender.

### 6.9 SCHEDULE OF EMD

EMD and all the documents asked in the tender (except price bid) shall be submitted with dully signed and stamp in physical on or before due date.	Address for Submission: Addl.General Manager (Materials & Contracts) Gujarat Industries Power Company Ltd P.O. Petrochemical – 391346 Dist.: Vadodara, Gujarat - India
--	---

### 7. SUBMISSION OF BIDS

#### A: MODE OF SUBMISSION

The Bids shall be submitted in two parts along with EMD within dates specified in NIT as under:-

- (a) Pre-qualification and Techno-commercial Bid without price.
- (b) Price Bid.

#### a) Pre-Qualification and Techno-commercial Bid without price:

The following Documents shall also be submitted along with EMD in Physical Form to GIPCL-Vadodara.

The following supporting documents shall also be submitted along with EMD in physical form:

1. The Tender Documents of (Section-A to Section-E ) duly signed in all pages without price bid along with techno-commercial deviations, if any shall accompany the bid. If you don't have deviations then write "NIL" in the deviation sheet and then submit with sign & stamp.
2. EMD in the form of DD/BG.



## **TENDER FOR PROCUREMENT OF BEND PIPE FOR REHEATER LINK (Bid No.: GIPCL/MATLS/BEND PIPE/2019-20)**

3. Proof of minimum eligibility criteria as per clause no.04 of Section A.

### **b) Price Bid:**

1) Price Bid shall be submitted only in soft form through **(n) Procure Only**.

## **8. EVALUATION & COMPARISON OF BIDS**

- 8.1** GIPCL shall evaluate the Bids received and accepted by it to ascertain the overall lowest/item wise lowest evaluated Bid in conformity with the specifications of the tender documents at his sole discretion.
- 8.2** The Technical Bids will be examined for minor matters regarding qualification of bids. Subsequent to correspondence with the respective bidders, the decision of GIPCL will be final.
- 8.3** All responses to requests for clarifications shall be in writing and shall be presented to the Company through e-mail or in a sealed envelope on or before the given date requested by the Company. If the Technical clarifications sought by the Company do not reach the Company on or before due date, the Bid will be rejected.
- 8.4** The comparison of all the Bids shall be carried out with reference to the scope of work as per the technical specification. Any deviation/omission shall be evaluated at highest quoted price of the deviation/omission quoted by any of the Bidder. In case a separate price (for omission) is not given by any other Bidder, a reasonable price of the same shall be taken & the same shall be binding to the Bidders.
- 8.5** The commercial deviation, if any, shall be loaded to bring all the Bids at par. The loading shall be carried out at an interest rate of 2% above PLR of SBI.
- 8.6** A Bid to be substantially responsive shall be one which on evaluation confirms to all the terms, conditions and specifications of the Bid documents without any material deviation or reservation.
- 8.7** For the above referred purpose, a 'material deviation' shall be one which:
- (a) Which affects in any substantial way the scope, quality or performance of the contract, or
  - (b) Which limits in any substantial way and in a manner inconsistent with the Bid documents, GIPCL's right or the Bidder's obligations, under the contract, or
  - (c) Whose rectification would affect unfairly the competitive position of other Bidders presenting substantially responsive Bids.

## **9. METHOD OF TENDERING/SIGNATURE ON BIDS**

- (i) The Bid must contain the postal address like name, residence and place of business of the person or persons submitting the Bid and must be signed and sealed by the Bidder with his usual signature. The name of all persons signing the documents shall also be typed or printed below the signature on each page.
- (ii) The Bidder's name stated on the proposal shall be the exact legal name of the firm.



## **TENDER FOR PROCUREMENT OF BEND PIPE FOR REHEATER LINK (Bid No.: GIPCL/MATLS/BEND PIPE/2019-20)**

- (iii) Erasures or other changes in the Bid Documents shall be initialed by the person signing the Bid.

### **10. MODIFICATION AND WITHDRAWAL OF BIDS**

- a. The Bidder may modify or withdraw the bid prior to the deadline prescribed for submission of bids.
- b. No Bid shall be modified subsequent to the deadline for submission of Bids.
- c. No Bid shall be withdrawn in the interval between the deadline for submission of Bids and the expiration of the period of bid validity.

### **11. POLICY FOR BIDS UNDER CONSIDERATION**

- a. Bid shall be deemed to be under consideration immediately after opening of the bid and till official intimation of award/rejection made by the Company to the Bidders.
- b. While the Bids are under consideration, Bidders and / or their representative or other interested parties are advised to refrain from contacting by any means, the Company. The Engineer, if necessary, will obtain clarifications on the Bids by requesting for such information from any or all the Bidders, in writing as may be necessary. The Bidder will not be permitted to change the price or substance of the Bid after the Bid has been opened.

### **12. EFFECT AND VALIDITY OF THE BID**

- a. The Bid should be kept valid for acceptance for a period of one hundred and eighty (180) calendar days from the last date of submission of Bids.
- b. The submission of any Bid along with the required documents and specifications shall constitute an agreement that the Bidder shall have no cause of action or claim, against the Company for rejection of his Bid. The Company shall always be at liberty to reject or accept any Bid or Bids at his sole discretion and any action will not be called into question and the Bidder shall have no claim in that regard against the GIPCL.

### **13. PRELIMINARY EXAMINATION OF BIDS**

13.1 The Company will examine the Bids for any computational errors, for sureties furnished by bidder, for authentication of documents submitted and completeness of the Bids.

13.2 Arithmetical errors will be rectified on the following basis:

- (a) If there is a discrepancy between the unit price and the total price that is obtained by multiplying the unit price and quantity, the unit price shall prevail and the total price will be corrected & will be binding to the bidders
- (b) If there is a discrepancy between the Total Bid Amount and the sum of total prices, the sum of total prices shall prevail and the Total Bid Amount will be corrected & will be binding to the bidders.



## **TENDER FOR PROCUREMENT OF BEND PIPE FOR REHEATER LINK (Bid No.: GIPCL/MATLS/BEND PIPE/2019-20)**

### **14. RIGHT OF REJECTION OF TENDERS**

14.1 GIPCL reserves the right to accept or reject any Bid or to cancel the Bidding process and reject all Bids at any time prior to award of contract, without thereby incurring any liability to the affected Bidder or Bidders or any obligation to inform the affected Bidder or Bidders regarding the same.

14.2 Any Tender without EMD will be treated as non responsive and shall be rejected at the outset & no further correspondence shall be entertained regarding this.

14.3 GIPCL reserves the right to debar any Bidder from participation in future Bids if such Bidder has quoted an abnormally low rate in the Bid document/price Bid.

### **15. AWARD OF CONTRACT**

15.1 GIPCL will award the contract to that bidder whose quotation has been determined to be substantially responsive and evaluated as the overall lowest quotation/item wise lowest quotation in conformity with the requirements of the specifications and documents contained herein, provided further that the bidder is determined and evaluated to be qualified to perform the contract satisfactorily at sole discretion of GIPCL.

15.2 The successful bidder shall be intimated of his selection through the Letter of Intent or Letter of Award/ Purchase Order which shall be sent to him through e-mail, courier, fax or registered mail.

15.3 GIPCL reserves the right to cancel/short close the contract during the contract period without assigning any reason.

15.4 GIPCL reserves the right to increase or decrease the qty. mentioned in tender inquiry before finalization of order.

15.5 GIPCL reserves the right to split the contract quantity between vendors.

### **16. CONTRACT PERIOD**

The contract will be valid till receipt of all materials mentioned in Section-D.

### **17. ASSIGNMENT AND SUB-LETTING**

The Supplier shall not directly or indirectly assign or sub-let total/any part of the contract to any other party or agency.



## **TENDER FOR PROCUREMENT OF BEND PIPE FOR REHEATER LINK (Bid No.: GIPCL/MATLS/BEND PIPE/2019-20)**

### **18. CLARIFICATION OF BIDDING DOCUMENTS**

If any Bidder requires any further information or clarification in the Bidding Documents, may notify the Company before one week of last date of submission of online Bid, in writing or by E-mail at the GIPCL's mailing address [bcshah@gipcl.com](mailto:bcshah@gipcl.com) as indicated in the 'Invitation to Bids'. The GIPCL's response (including an explanation of the query) will be sent in writing or by E-mail to all prospective Bidders who have received the Bidding Documents.

### **19. UNDERSTANDING AND CLARIFICATION ON DOCUMENTS AND SPECIFICATION**

The Bidder is required to carefully examine the specifications and documents, all the conditions and matters work wise & cost wise. If any Bidder finds any discrepancies or omissions in the specifications and documents or is in doubt for any meaning of any part, he shall request in writing for an interpretation/ clarification to the GIPCL.

All such interpretations and clarifications shall form a part of the Bid documents.

### **20. PAYMENTS**

All the payments against the work order shall be in Indian currency and payable through cheque/RTGS.



**TENDER FOR PROCUREMENT OF BEND PIPE FOR REHEATER LINK  
(Bid No.: GIPCL/MATLS/BEND PIPE/2019-20)**

**SECTION-B**

**INSTRUCTIONS TO BIDDERS FOR ONLINE TENDERING**

Sr. No	Description
01.	Tender documents are available only in electronic format which Bidders can download from the website <a href="https://www.nprocure.com">https://www.nprocure.com</a> and <a href="https://gipcl.nprocure.com">https://gipcl.nprocure.com</a> and It can also be viewed from Company's website <a href="http://www.gipcl.com">www.gipcl.com</a> .
02.	Price bid should be submitted online through the website <a href="https://gipcl.nprocure.com">https://gipcl.nprocure.com</a> only. No physical submission of price bid will be entertained as it should be furnished on-line only.
03.	Bidders who wish to participate in online tenders will have to procure / should have legally valid Digital Certificate (Class III) as per Information Technology Act-2000, using which they can sign their electronic bids. Bidders can procure the same from any of the license certifying Authority of India or can contact (n)code solutions- a division of GNFC Limited, who are licensed Certifying Authority by Government of India
04.	All bids should be digitally signed. The bidders are required to contact at the below mentioned address for detailed training on on-line tendering and also for requirement.  (n) Code Solutions - A division of GNFC Ltd. 403, GNFC Infotower, S.G Road, Bodakdev, Ahmedabad – 380054 (Gujarat, India)  Toll Free: 1-800-419-4632/1-800-233-1010, Tel: 079-26857315/316/317 E-mail: <a href="mailto:nprocure@gnvfc.net">nprocure@gnvfc.net</a> , website: <a href="http://www.nprocure.com">www.nprocure.com</a>

**Interested bidders are requested to submit the online tender at least two days in advance from the due date set for on line submission of bid in order to avoid non participation.**



**TENDER FOR PROCUREMENT OF BEND PIPE FOR REHEATER LINK  
(Bid No.: GIPCL/MATLS/BEND PIPE/2019-20)**

**REVERSE AUCTION:**

- 1) GIPCL reserves the right to conduct E-Reverse auction through (n) Procure platform.
- 2) E-Reverse auction shall be conducted amongst (a) the lowest 50% eligible bidders (rounded to the next higher whole number) from the total bids received OR (b) Minimum three (03) lowest bidders, whichever is higher, shall be invited for participation in e-Reverse Auction through n-procure platform.
- 3) Opening Price, Detrimental value and duration for the e-Reverse Auction shall be informed to the qualified bidders before start of e-Reverse Auction.
- 4) After e-Reverse Auction process, L1 bidder shall be decided on Lowest Total Contract Price.
- 5) To participate in e-Reverse Auction, Bidders have to create e-Auction USER ID on <https://e-auction.nprocure.com> that the bidder shall be allowed to participate the e-Reverse Auction.
- 6) In case of any further information regarding online bidding or if a Bidder needs any assistance in accessing/ submission of online bid/ clarification or if training is required for participating in online e-reverse bidding, then the Bidder can contact the following office for assistance or training:

(n) Procure Cell, (n) code solutions-A division of GNFC Ltd.,

403, GNFC Info tower, S.G. Road,  
Bodakdev Ahmedabad – 380054 (Gujarat)  
Toll Free: 1-800-419-4632 / 1-800-233-1010,  
Phone No. 079-26857315 / 316 / 317,  
Fax: 079-26857321 / 40007533, Email: [nprocure@gnvfc.net](mailto:nprocure@gnvfc.net)  
Bidder may visit <https://www.nprocure.com/html/faq.asp> for information regarding e tendering registration process.



**TENDER FOR PROCUREMENT OF BEND PIPE FOR REHEATER LINK  
(Bid No.: GIPCL/MATLS/BEND PIPE/2019-20)**

**SECTION-C  
GENERAL CONDITIONS OF CONTRACT**

**1) CONTRACT SECURITY DEPOSIT/ PERFORMANCE BANK GUARANTEE**

As a Contract Security, the successful Bidder, to whom the work is awarded, shall be required to furnish a Performance Bank Guarantee (PBG)/Contract security deposit in favor of Gujarat Industries Power Company Limited for guarantee amount at 10% of the Purchase Order Value (excluding Taxes & Duties) valid for 18 months from the date of receipt of materials at site from any Schedule Public Sector Bank or Schedule Private Sector Bank in the format attached in SECTION-E, and it shall guarantee the faithful performance of the 'Contract' in accordance with the terms and conditions specified in these documents and specifications. Any defect or poor workmanship found during guarantee period, vendor shall replace the Material at free of cost. GIPCL reserves the right to forfeit Performance Bank Guarantee (PBG)/Contract security deposit.

PBG/Contract Security deposit shall be submitted within Fifteen (15) days from date of receipt of materials at site.

The (PBG)/Contract security will be returned to the Supplier without any interest after successful completion of guarantee period and on fulfilling contractual obligations throughout the period. However, any delay in submission of initial SD may result in equivalent late release of entire SD after guarantee period.

**2) PRICE**

Price quoted by the bidder should be firm and no price increase will be allowed to the supplier. The Bidder should quote price on free delivery at GIPCL-SLPP Plant on door delivery basis. Prices will be inclusive of inspection, packing and forwarding, transportation, transit Insurance, Octroi, Stacking, Loading/unloading and any other charges etc. However applicable GST shall be paid extra at actual.

**3) PRE- DISPATCH INSPECTION**

GIPCL may carry out Pre dispatch inspection. Bidder shall inform 15 days in advance for pre dispatch inspection.

**4) DELIVERY AND LIQUIDITY DAMAGE**

Bidder should Supply Materials within **Twelve Weeks** (12 Weeks) from date of issue of PO from GIPCL failing which LD/ penalty @ 0.5% per week (07 days) per order value/item value (excluding T&D) shall be levied by GIPCL for late supply / undelivered items maximum up to 10% of items value under order. Material should be directly delivered to GIPCL-SLPP from your works.

Delivery is the essence of the contract and if the delivery is not made as stipulated, GIPCL shall be at liberty to procure the material at Bidder's risk and cost and if hereby any extra expenditure is involved, the same will be debited to Bidder's





## **TENDER FOR PROCUREMENT OF BEND PIPE FOR REHEATER LINK (Bid No.: GIPCL/MATLS/BEND PIPE/2019-20)**

account. If GIPCL is unable to procure the material from other source in time and if GIPCL suffers any consequential loss, Bidder will have to bear the same. GIPCL in that case (if the delivery is not made as stipulated) will forfeit Security Deposit / Performance Bank Guarantee or EMD and can also lodge claim against bidder for damage incurred.

### **5) TEST CERTIFICATE**

Bidder shall furnish material test certificate along with supply. Certificate shall be well known Tube/pipe maker, Form III A (certificate of manufacturer and test) as per regulation 4e.

### **6) PAYMENT TERM**

100% of the order value of the supplied lot of materials will be released within 30 days from receipt of materials at site, after submission of PBG and acceptance by user department after verification documents like Material Test Certificates (Mentioned in Section-D), original invoices etc, if any as per the PO terms.

### **7) GUARANTEE**

Guarantee period shall be 12 months from the date of installation/commissioning or 18 months from the date of receipt at GIPCL-SLPP whichever is earlier. Any defects/problems arising during Guarantee period, Bidder has to rectify the same at their cost & risk.

### **8) LOSS AND DAMAGES**

Any loss or damages and deterioration to the material in transit shall be at the cost of the suppliers. It shall be at the discretion of the GIPCL to reject the damaged or spoilt material, if so noticed.

### **9) INVOICE**

Original invoice should be sent at GIPCL- Baroda and duplicate invoice along with challan should be sent at GIPCL-SLPP Store. (Mention the Purchase Order No. in Invoice and challan)

### **10) APPROVAL**

The Material supplied will be subject to GIPCL approval and inspection at GIPCL-SLPP premises. Our decision for acceptance or rejection of the goods will be final and binding on you.

### **11) TRANSIT INSURANCE**

The goods supplied under the contract shall be fully insured against loss or damage incidental to manufacture or acquisition, transportation, storage and delivery to destination. Insurance is to be provided by the supplier at his cost.



## **TENDER FOR PROCUREMENT OF BEND PIPE FOR REHEATER LINK (Bid No.: GIPCL/MATLS/BEND PIPE/2019-20)**

### **12) QUANTITY OF SUPPLIED MATERIAL:**

Quantity recorded at GIPCL-SLPP Store will be taken as the basis of payment.

### **13) TERMINATION OF CONTRACT BY GIPCL**

Supplier shall be responsible to complete the jobs within agreed time schedule and in case Supplier fails to complete the job, GIPCL shall recover from his bill, Security Deposit and / or whatsoever for expenses incurred to complete the job with additional 15% overhead charges.

In case if Supplier's services are not found satisfactory with respect to time bound completion of work, workmanship then GIPCL has right to terminate the contract at any time by giving him 15 days advance notice without assigning any reason and will make the alternate arrangement at the risk & cost of Supplier.

GIPCL may terminate the contract after due recoveries of pending jobs/damages after giving 15 days advance notice to the Supplier if any of the following events occur –

- i. Supplier is adjudged as insolvent.
- ii. Supplier has abandoned the contract.
- iii. Supplier fails to proceed with the work with due diligence as per requirements of the contract.
- iv. Supplier has neglected or failed persistently to observe or perform any of the acts, matters or things, which as per the contract are to be observed and performed by the Supplier.
- v. Supplier repetitively violating the safety norms for more than three incidents.
- vi. Any major contradiction of applicable labour laws.
- vii. Any major deviations from contractual terms and conditions including quality of job.
- viii. GIPCL reserves the right to terminate the contract without giving any reason whatsoever.

### **14) FAILURE & TERMINATION**

f the SUPPLIER after receipt of written notice from the GIPCL/ ENGINEER requiring compliance, with such further drawings and / or the GIPCL /ENGINEER instructions fails within seven days to comply with the same, the GIPCL /ENGINEER may employ and pay other agencies to execute any such work whatsoever as may be necessary to give effect thereto and all costs incurred in connection therewith shall be recoverable from the SUPPLIER by the GIPCL on a certificate by the GIPCL/ENGINEER as a debt or may be deducted by him from any money due or to become due to the SUPPLIER.

If the contractor fails to execute the work or fails to mobilize the resources and equipments as per directions of GIPCL / ENGINEER within the time frame given and/or violating the GIPCL's safety rules & regulations, ENGINEER/ GIPCL shall get the work done by third party at the risk & cost of the CONTRACTOR with additional 15% overhead charges of GIPCL and all costs incurred in connection therewith shall be



## **TENDER FOR PROCUREMENT OF BEND PIPE FOR REHEATER LINK (Bid No.: GIPCL/MATLS/BEND PIPE/2019-20)**

recoverable from the CONTRACTOR by the GIPCL /ENGINEER as a debt or may be deducted by him from any money due or to become due to the CONTRACTOR.

In case if contractor's services are not found satisfactory with respect to mobilization, time bound material evacuation, workmanship & safety (OHSAS policy of GIPCL) then GIPCL has rights to terminate the contract at any time by giving you 15 days advance notice without assigning any reason and will make the alternate arrangement at cost and risk of the Contractor.

### **15) SETTLEMENT OF DISPUTES**

- a. Any disputes or difference of opinion between parties arising out of the contract to the extent possible shall be settled amicably between the parties. If amicable settlement cannot be reached all the disputed issues shall be resolved through arbitration before a Sole Arbitrator appointed by Managing Director, GIPCL according to the provisions of The Arbitration & Conciliation Act, 1996. The place of arbitration shall be at Vadodara or any other place within state of Gujarat as may be mutually agreed by the parties in consultation with the tribunal.
- b. In appointment of the Sole Arbitrator, if the dispute claim is up to a sum of Rs. 25/- Lac, a person having a position equivalent to a Retired District Judge shall be appointed; for the claim higher than Rs. 25/- Lac and up to Rs. 100/- Lac, the same shall be referred to a Retired High Court Judge and for a claim exceeding Rs. 100/- Lac, the same shall be referred to a Retired Supreme Court Judge.
- c. Work under the contract shall be continued by the contractor during arbitration proceedings unless GIPCL shall order suspension thereof or any part thereof in writing or unless the matter in such work cannot possibly be continued unless the decision of the Arbitration proceedings is obtained.

### **16) INTERPRETATION OF CLAUSE**

In case of disputes as regards interpretation of any of the clauses or specification, the decision of GIPCL will be final and binding on the Supplier.

### **17) FORCE MAJEURE**

The performance of the obligations herein contemplated may be suspended without incurring the penalty in the event of the subsistence of Force Majeure conditions.

If a Force Majeure situation arises, the affected Party shall promptly notify the other Party in writing of such conditions and the performance shall be suspended as per mutual agreement.

For the purposes of this clause, 'Force Majeure' means an event beyond the control of the Party and not foreseeable by the Party and shall include events of floods, explosions, riots, wars, hurricane, epidemics, any other Act of God, quarantine restrictions, terrorism, government actions and provided always that such acts result in the impossibility of the further performance of the contract.



**TENDER FOR PROCUREMENT OF BEND PIPE FOR REHEATER LINK  
(Bid No.: GIPCL/MATLS/BEND PIPE/2019-20)**

**18) INDEMNITY**

The Supplier shall indemnify and keep harmless GIPCL from and against all actions, proceedings, claims, demands, losses, costs, damages and expenses whatsoever which may be brought against or suffered by GIPCL which it may sustain, pay or incur as a result of or in connection with the performance/ purported performance/ non-performance of the contract by the Supplier.

In case, in any litigation pertaining to labour employed through Supplier if any direction or order is issued by court at any point of time the Supplier shall comply with and implement such direction or order whether passed at the time of award of contract or during the pendency of contract. Further, the Supplier shall indemnify the GIPCL against all consequences arising and affecting GIPCL owing to the compliance of the orders by the Supplier.

**19) GOVERNING LAW AND JURISDICTION**

This tender document and contract shall be governed by the laws of India and the Courts at Vadodara shall have jurisdiction regarding the same.



**TENDER FOR PROCUREMENT OF BEND PIPE FOR REHEATER LINK  
(Bid No.: GIPCL/MATLS/BEND PIPE/2019-20)**

**SECTION-D, TECHNICAL DETAILS & PRICE BID SCHEDULE**

**1) PRICE SCHEDULE**

<b>Sr No</b>	<b>Item Code</b>	<b>Description</b>	<b>Qty in (NO)</b>	<b>Unit Cost</b>	<b>GST (IN %)</b>	<b>Total Cost</b>
1	710104174	BEND PIPE OF REHEATER LINK  Pipe OD: 609.6 X 30 mm (thickness), MOC: SA 335 P 22.	2.00			<b>Prices shall be quoted online through (n) Procure only.</b>

**All above prices shall be quoted through online (n)-Procure only; Hard copy of price bid shall not be considered/accepted.**



**TENDER FOR PROCUREMENT OF BEND PIPE FOR REHEATER LINK  
(Bid No.: GIPCL/MATLS/BEND PIPE/2019-20)**

**2) TECHNICAL SPECIFICATIONS**

**Pipe Specifications (*Item Code –710104174*):**

- a. Bend Pipe of Re-heater Link.
- b. Seamless pipe ASME SA 335 Grade P22.
- c. Size: OD –609.6 MM, Thickness – 30.00 MM.
- d. 90 Degree Bend pipe.
- e. Design Pressure: 38.5 Kg/Cm<sup>2</sup>(g)
- f. Design Temperature : 524 °C
- g. Heat Treatment as per IBR.
- h. Hydro test as per IBR.
- i. Tolerance on OD and Thickness: As per IBR and specification.
- j. Ends: As per ASME B16.25
- k. Standard : ASME B 16.49 ( latest version)
- l. Design, Manufacturing and inspection as per IBR.

**Other technical requirement:**

- a. GIPCL shall witness hydraulic test of pipes. Bidder shall inform to GIPCL well in advance.
- b. Well Known Pipe Manufacturers shall be in the Approved List of Chief Inspector of Indian Boilers.
- c. Party shall submit “Well Known Tube/Pipe Maker FORM III A (certificate of manufacture and test) Regulation 4e”.
- d. Marking : Each bend shall be marked on the outside surface of one end to show the following:
  - 1) Manufacture’s name or trade mark
  - 2) Heat Number
  - 3) Material grade symbol
  - 4) ASME B 16.49
  - 5) Nominal size
  - 6) Nominal wall thickness
  - 7) Bend Radius
  - 8) Bend Angle
  - 9) Post bending heat treatment condition.
  - 10) Hydraulic test Pressure
- e. Both ends of tube shall be suitably protected to protect End (Edge of pipe).
- f. The external surface of the each pipe shall be coated with high temperature paint as per standard practice.
- g. GIPCL has right to conduct any test of pipe from Govt. Approved laboratory and results of same shall be bound to supplier. Supplier may witness the same.

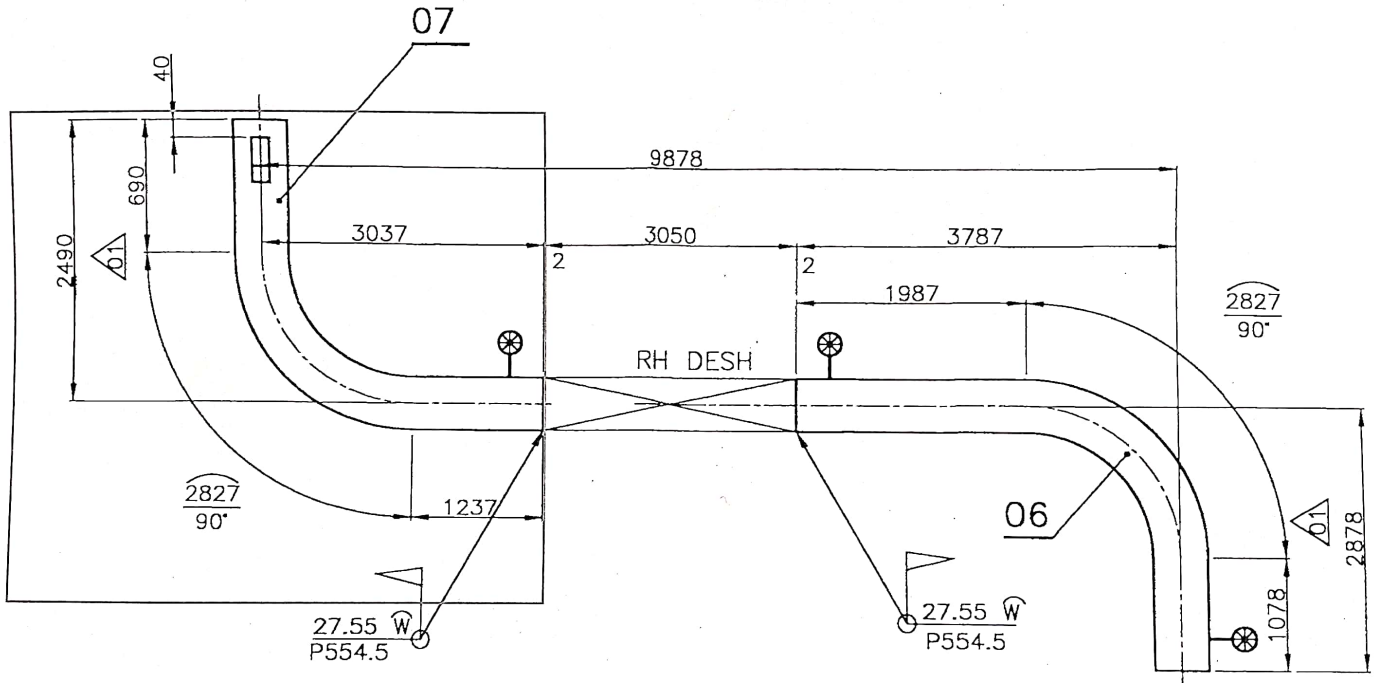

Pipe Bend: Pipe OD:609.6 X 30mm ,  
 MOC: SA 335 P22  
 Total Length: 690mm + Arc 2827mm + 1237mm =  
 4754mm,

Reheater Link Pipe. = PH:II Boilers



**TENDER FOR PROCUREMENT OF BEND PIPE FOR REHEATER LINK  
(Bid No.: GIPCL/MATLS/BEND PIPE/2019-20)**

**SECTION-E**

**1.0 ANNEXURE-A**

**PROFORMA FOR BANK GUARANTEE FOR EARNEST MONEY DEPOSIT**

(To be executed on non-judicial stamped paper of appropriate value)

B. G. No. \_\_\_\_\_ Date: \_\_

1. WHEREAS M/s.Gujarat Industries Power Company Limited having its Corporate Office at PO: Petrochemicals, Dist.Vadodara – 391 346, Gujarat State, India (hereinafter called “The Company Owner” which expression shall unless repugnant to the subject or context includes its legal representatives, successors and assigns) has issued tender paper vide its Tender No.....for \_\_\_\_\_ (hereinafter called “the said tender”)to M/s.....(hereinafter called the said Tenderer(s)” which expression shall unless repugnant to the subject or context includes their legal representatives, successors and assigns and as per terms and conditions of the said tender, the tenderer shall submit a Bank guarantee for Rs..... (Rupees.....only) towards earnest money in lieu of cash.
2. We .....Bank having its branch office at ..... do hereby undertake to pay the amount due and payable under this guarantee without any demur, merely on a demand from the Company stating that in the opinion of the company which is final and binding, the amount claimed is due because of any withdrawal of the tender or any material alteration to the tender after the opening of the tender by way of any loss or damage caused to or would be caused or suffered by the Company by reason of any breach by the said tenderer(s) of any of the terms and conditions contained in the said tender or failure to accept the letter of Intent Agreement or that the amount covered under this Guarantee is forfeited. Any such demand made on the Bank by the owner shall be conclusive as regards the amount due and payable by the Bank under this guarantee, However, our liability under this guarantee shall be restricted to an amount not exceeding Rs.....(Rupees.....only).
3. We undertake to pay to the Company any money so demanded not withstanding any dispute or disputes raised by the tenderer (s) in any suit or proceeding pending before any office, court or tribunal relating thereto our liability under this present guarantee being absolute and unequivocal. The payment so made by us under this bond shall be a valid discharge of our liability for payment there under. Our liability to pay is not dependent or conditional on the owner proceeding against the tenderer.
4. The guarantee herein contained shall not be determined or affected or





**TENDER FOR PROCUREMENT OF BEND PIPE FOR REHEATER LINK  
(Bid No.: GIPCL/MATLS/BEND PIPE/2019-20)**

suspended by the liquidation or winding up, dissolution or change of constitution or insolvency of the said tenderer(s) but shall in all respect and for all purposes be binding and operative until payment of all money due or liabilities under the said contract(s)/ Order(s) are fulfilled.

5. We .....Bank Ltd. further agree that the guarantee herein contained shall remain in full force and effect during the period that would be taken for the finalization of the said tender and that it shall continue to be enforceable till the said tender is finally decided and order placed on the successful tenderer(s) and or till all the dues of the company under or by virtue of the said tender have been fully paid and its claims satisfied or discharged or till a duly authorized officer of the company certifies that the terms and conditions of the said tender have been fully and properly carried out by the said tenderer (s) and accordingly discharges the guarantee.
6. That the Owner Company will have full liberty without reference to us and without affecting this guarantee to postpone for any time or from time to time the exercise of any of the power of the owner under the tender.
7. Notwithstanding anything contained herein before, our liability shall not exceed Rs..... (Rupees.....only) and shall remain in force till..... (Date to be filled up shall be 180 days from the date of submission of Bid).

Date.....

..... Bank  
Corporate Seal of the Bank By  
its constitutional Attorney

Signature of duly Authorized  
person On behalf of the Bank  
With Seal & Signature code



**TENDER FOR PROCUREMENT OF BEND PIPE FOR REHEATER LINK  
(Bid No.: GIPCL/MATLS/BEND PIPE/2019-20)**

**2.0 ANNEXURE-B**

**PROFORMA FOR CONTRACT SECURITY-CUM-PERFORMANCE GUARANTEE BY  
SELLER / CONTRACTOR.**

(To be executed on non-judicial stamped paper of approximate value)

B. G. No. \_\_\_\_\_ Date: \_\_\_\_\_

1. WHEREAS Gujarat Industries Power Company Limited having its office at PO: Petrochemicals, Dist. Vadodara – 391 346, Gujarat State, India (hereinafter referred to as “The Company/Owner” which expressions shall unless repugnant to the subject or context includes its legal representatives, successors and assigns) has entered into a contract with M/s. .... / has placed a purchase order on M/s.....(hereinafter referred to as “Contractor(s)/ Seller(s)” which expression shall unless repugnant to the subject or context includes their legal representatives, successors and assigns ) for .....on the terms and conditions as set out inter alia, in the Company’s contract No./ P.O.No.....date .....and various documents forming part thereof hereinafter referred to as the “said contract” which expression include all amendments, modifications and/ or variations thereto and where as the Contractor(s)/ Seller(s) has agreed for due execution of the entire contract and guarantees its performance including any parts executed through any other agencies/ subcontractors

AND WHEREAS one of the conditions of the “said contract” is that “contractor(s)/seller(s) shall furnish to the owner a Bank Guarantee from a bank for ...% (.....percent) of the total value of the “said contract” against due and faithful performance of the “said contract” including performance guarantee obligations of the contractor(s)/seller(s) for execution/ supplies made under the “said contract.”

2. We .....Bank having its branch office at .....do hereby agree and undertake to pay the amount due and payable under this guarantee without any demur merely on a demand from the Company stating that in the opinion of the Company, which is final & binding, the amount claimed is due by reason of default made by the Contractor(s)/ Seller(s) in performing any of the terms & conditions of the said Contract including defect liability obligations, in fulfilling the performance guarantee obligation or loss or damage caused to or would be caused to or suffered by the Company by reason of any breach by the said Contractor (s)/ Seller(s) of any of the terms & conditions of the contract. Any

such demand made on the Bank by the owner shall be conclusive as regards the



**TENDER FOR PROCUREMENT OF BEND PIPE FOR REHEATER LINK  
(Bid No.: GIPCL/MATLS/BEND PIPE/2019-20)**

amount due and payable by the Bank under this guarantee. However our liability under this guarantee shall be restricted to Rs. ....(Rupees.....only).

3. We undertake to pay to the Company any money so demanded not withstanding any dispute or disputes raised by the contractor(s)/ Seller(s) in any suit or proceeding pending before any office, court or tribunal relating thereto our liability under this present guarantee being absolute and unequivocal. The payment so made by us under this bond shall be a valid discharge of our liability for payment there under. Our liability to pay is not dependent or conditional on the owner proceeding against the Contractor(s)/ Seller(s).
4. The guarantee herein contained shall not be determined or affected or suspended by the liquidation or winding up, dissolution or change of constitution or insolvency of the said Contractor(s)/ Seller(s) but shall in all respect and for all purposes be binding and operative until payment of all money due or liabilities under the said contract(s)/ Order(s) are fulfilled.
5. This guarantee will remain valid up \_\_\_\_\_ days or \_\_\_\_\_ whichever is earlier. The Bank undertakes not to revoke this guarantee during its currency without previous consent of the OWNER/PURCHASER and further agrees that if this guarantee is extended for a period as mutually agreed between bidder & owner/purchaser, the guarantee shall be valid for a period so extended provided that a written request for such extension is received before the expiry of validity of guarantee.
6. We .....Bank further agree with the Company that the company shall have the fullest liberty without our consent and without affecting in any manner our obligations hereunder to vary any of the terms and conditions of the said Contract(s)/ Order(s) or to extend the time of performance by the said Contractor(s) Seller(s) from time to time or to postpone for any time or from time to time any of the powers exercisable by the Company against the said Contractor(s)/ Seller(s) and to forbear or enforce any of the terms and conditions relating to the said Contract(s)/ Order(s) and we shall not be relieved from our liability by reason of any such variation, or extension being granted to the said Contractor (s) / Seller(s) or for any forbearance, act or omission on the part of the Company or any indulgence by the Company to the said Contractor(s)/ Seller(s) or by any such matter or thing whatsoever which under the law relating to sureties would, but for this provision, have affect of so relieving us.
7. Notwithstanding anything contained herein before, our liability shall not exceed Rs.....(Rupees.....only) and shall remain in force till.....Unless a demand or claim under this Guarantee is made on us within three months from



**TENDER FOR PROCUREMENT OF BEND PIPE FOR REHEATER LINK  
(Bid No.: GIPCL/MATLS/BEND PIPE/2019-20)**

the date of expiry we shall be discharged from all the liabilities under this guarantee.

Date.....

.....Bank

Corporate Seal of the Bank

By its constitutional Attorney  
Signature of duly Authorized  
person

On behalf of the Bank

With Seal & Signature code



**TENDER FOR PROCUREMENT OF BEND PIPE FOR REHEATER LINK  
(Bid No.: GIPCL/MATLS/BEND PIPE/2019-20)**

**3.0 ANNEXURE-C**

**Schedule of Deviation from Technical Specification and Commercial Terms and Conditions**

All the deviations from the terms & conditions of contract shall be filled by BIDDER clause by clause in this schedule.

Sr. No	SECTION	CLAUSE NO	AS TENDER DOCUMENT	PER DEVIATION
COMPANY SEAL				
SIGNATURE-----				
NAME-----				
DESIGNATION---				
COMPANY----				
DATE ----				

The bidder here by certifies that the above mentioned are the only deviations from OWNER's Tender enquiry. The bidder further confirms that in the events any other data and information presented in the BIDDER's proposal and accompanying documents are at variance with specific requirements laid out in the OWNER's Tender Document, then the latter shall govern and will be binding on the BIDDER for quoted price.



**TENDER FOR PROCUREMENT OF BEND PIPE FOR REHEATER LINK  
(Bid No.: GIPCL/MATLS/BEND PIPE/2019-20)**

**4.0 ANNEXURE- D**

**Declaration for Contractual Disputes/ Litigations**

*(To be submitted on Company's Letter Head)*

I \_\_\_\_\_ on behalf of .....Name of Party/Company.....hereby confirm that I/We have not been engaged in any Industrial Dispute(S) or have invoked legal recourse e.g. Arbitration and/or litigation against any Govt, of Gujarat Undertakings / Depts. / Authorities and Govt. of Gujarat supported companies / undertakings / organizations for the last Five (05) years. There are no ongoing/pending legal matter(s) with any of the Govt. of Gujarat Undertakings / GoG supported Companies, including GIPCL.

I/We also confirm that M/s ..... Have not been Blacklisted/ deregistered / listed under stop Deal by any Govt, of Gujarat Undertakings / Depts. / Authorities and Govt. of Gujarat supported companies / undertakings / organizations , including GIPCL for the last Five (05) years.

The above is true, as on date, to the best of my knowledge. Any breach/ false statement in this regard shall amount to disqualification of the Bid being submitted herein.

Signed and Stamped by the

Authorized Signatory  
Of the Bidder



**TENDER FOR PROCUREMENT OF BEND PIPE FOR REHEATER LINK  
(Bid No.: GIPCL/MATLS/BEND PIPE/2019-20)**

**5.0 ANNEXURE- E**

**PARTICULARS OF THE BIDDER**

<b>Sr. No.</b>	<b>Particulars</b>	<b>Please provide information here.</b>
1.	Name of Bidder	
2.	a. Registered Office Address:  b. Address for Correspondence:  c. E-mail ID:	
3.	Contact Details:  Contact Person Name  Telephone No. :  Mobile No.:	
4.	Year of establishment  PAN No.  GST No	

COMPANY SEAL

SIGNATURE .....

NAME .....

DESIGNATION .....

COMPANY .....

DATE .....